

PHILIPS

TownTune Central Post-Top

BDP260/261/262/263



BDP260



BDP262



BDP261

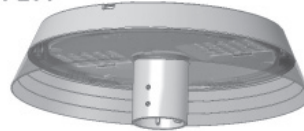

BDP263



220V
240V

50Hz
60Hz



IEC
EN60598



IP66

IK10

LEDs



Max.
35 °C
Min.
-40°C



4-8m



Standard luminaire housing BDP260 is IK10. Added accessories are rated at IK08.

As accessories are not a structural part of the luminaire housing, the IK rating for the luminaire housing remains IK10.

Photobiological Risk
Luminaire Surge Protection
Luminaire Surge Protection with SPD *optional

RG1 (valid for Neutral and Warm White)
DM/CM 6/8 kV (C-I/C-II)
DM/CM 10/10 kV (C-I) - 10/8 kV (C-II) - 10/10 kV (C-II) (optional ground for installer)



LEDs

W
+/-10%

Source
+/-7%

Efficiency
Class



m²

kg

740

LED color	LED gine	LEDs	W +/-10%	Source +/-7%
LED14	12	12	9,3	1400
LED16	12	12	10,4	1600
LED18	12	12	11,6	1800
LED20	12	12	12,8	2000
LED22	12	12	14	2200
LED24	12	12	15,4	2400
LED27	12	12	17,2	2700
LED30	12	12	19,2	3000
LED35	12	12	22,5	3500
LED39	20	20	24	3900
LED45	20	20	28	4500
LED50	20	20	31	5000
LED55	20	20	34,5	5600
LED59	20	20	37	6000
LED64	20	20	40,5	6400
LED69	40	40	40,5	7000
LED74	40	40	43	7400
LED79	40	40	46	8000
LED84	40	40	49,5	8400
LED90	40	40	53	9000
LED94	40	40	55	9400
LED100	40	40	59	10000

D



0,042

6,8kg*











583 - 443000020784 C
2021-07-23
© SignifyHolding
All rights reserved



Efficiency Class



	LED color	LED line	LEDs	W +/- 10%	Source +/- 7%	Efficiency Class			m ²	kg
	LED14		12	9,8	1400					
	LED16		12	11	1600					
	LED18		12	12,4	1800					
	LED20		12	13,6	2000					
	LED22		12	14,8	2200					
	LED24		12	16,2	2400					
	LED27		12	18,4	2700					
	LED30		12	20,5	3000					
	LED35		12	24	3500					
730	LED39		20	25,5	3900					
	LED45		20	29,5	4500	D	✓	✓	0,042	6,8kg*
	LED50		20	33	5000					
	LED55		20	36,5	5600					
	LED59		20	39,5	6000					
	LED64		40	39,5	6400					
	LED69		40	43	7000					
	LED74		40	46	7400					
	LED79		40	49	8000					
	LED84		40	52	8400					
	LED90		40	56	9000					
	LED94		40	59	9400					
	LED14		12	10,8	1400					
	LED16		12	12,2	1600					
	LED18		12	13,6	1800					
	LED20		12	15	2000					
	LED22		12	16,4	2200					
	LED24		12	18	2400					
	LED27		12	20,5	2700					
	LED30		12	23	3000					
	LED35		12	27	3500					
727	LED39		20	28,5	3900					
	LED45		20	33	4500	E	✓	✓	0,042	6,8kg*
	LED50		20	37	5000					
	LED55		20	41	5600					
	LED59		40	40,5	6000					
	LED64		40	44	6400					
	LED69		40	47,5	6800					
	LED74		40	51	7400					
	LED79		40	55	8000					
	LED84		40	58	8400					

					Efficiency Class				
722	LED12	12	10,8	1200	E	✓	✓	0,042	6,8kg*
	LED14	12	12,4	1400					
	LED16	12	14	1600					
	LED18	12	15,6	1800					
	LED20	12	17,6	2000					
	LED22	12	19,4	2200					
	LED24	12	21	2400					
	LED27	12	24	2700					
	LED30	12	27	3000					
	LED35	20	29,5	3500					
	LED39	20	33	3900					
	LED45	20	39	4500					
	LED50	40	40	5000					
	LED55	40	44	5600					
	LED59	40	47,5	6000					
	LED64	40	52	6400					
	LED69	40	56	7000					
LED74	40	60	7400						
827	LED12	12	10,8	1200	E	✓	✓	0,042	6,8kg*
	LED14	12	12,4	1400					
	LED16	12	14	1600					
	LED18	12	15,8	1800					
	LED20	12	17,6	2000					
	LED22	12	19,4	2200					
	LED24	12	21	2400					
	LED27	12	24	2700					
	LED30	20	25,5	3000					
	LED35	20	29,5	3500					
	LED39	20	33	3900					
	LED45	20	39	4500					
	LED50	40	40	5000					
	LED55	40	44	5600					
	LED59	40	47,5	6000					
	LED64	40	52	6400					
	LED69	40	56	7000					
840	LED12	12	9,8	1200	E	✓	✓	0,042	6,8kg*
	LED14	12	11,2	1400					
	LED16	12	12,8	1600					
	LED18	12	14,2	1800					
	LED20	12	15,8	2000					
	LED22	12	17,4	2200					
	LED24	12	19	2400					
	LED27	12	21,5	2700					
	LED30	12	24	3000					
	LED35	20	26,5	3500					
	LED39	20	30	3900					
	LED45	20	34,5	4500					
	LED50	20	39	5000					
	LED55	40	40	5600					
	LED59	40	42,5	6000					
	LED64	40	46,5	6400					
	LED69	40	50	7000					
LED74	40	54	7400						
LED79	40	58	8000						



Efficiency Class



	LED color	LED gine	LEDs	W +/-10%	Source +/-7%	Efficiency Class	Mounting	m²	kg	
	LED12		12	10	1200					
	LED14		12	11,6	1400					
	LED16		12	13,2	1600					
	LED18		12	14,6	1800					
	LED20		12	16,2	2000					
	LED22		12	18	2200					
	LED24		12	19,6	2400					
	LED27		12	22	2700					
	LED30		12	25	3000					
830	LED35		20	27,5	3500	E	✓	✓	0,042	6,8kg*
	LED39		20	31	4000					
	LED45		20	36	4500					
	LED50		20	40,5	5000					
	LED55		40	41	5600					
	LED59		40	44	6000					
	LED64		40	48	6400					
	LED69		40	52	7000					
	LED74		40	56	7400					
	LED79		40	60	8000					

Surface to the wind (m²) without embellishment accesories

* Weight without mounting devices

Weight of decorative ring 0,6 kg

Weight of top accessory cone 1,1 kg

Weight of top accessory dome 0,8 kg

Temperature protection:

The LED drivers have temperature protection circuits to switch off the output when the device gets too warm.

Power will return automatically when the temperature has dropped again.

Remark:

Photometric data will be provided upon customer request.



WARNING

This luminaire must be installed only by qualified personnel.
If the external flexible cable or cord of this luminaire is damaged, it shall be exclusively replaced by the manufacturer or his service agent or a similar qualified person in order to avoid a hazard.

The light source contained in this luminaire shall only be replaced by the manufacturer or his service agent or a similar qualified person



Disconnect before servicing



Use gloves to manipulate the luminaire



The space between lyre and luminaire could be a pinch point
Keep hands clear during operation.



Free rotation of the lyre can cause damage in painted parts



Follow this mounting instructions to fix install and maintain



Never modify the luminaire or the fixations



Risk of accident due to incorrect tightening torque

TOWNTUNE CENTRAL POST-TOP
(Wind surface $0,042\text{m}^2$ / $\text{SCx } 0,033\text{m}^2$)

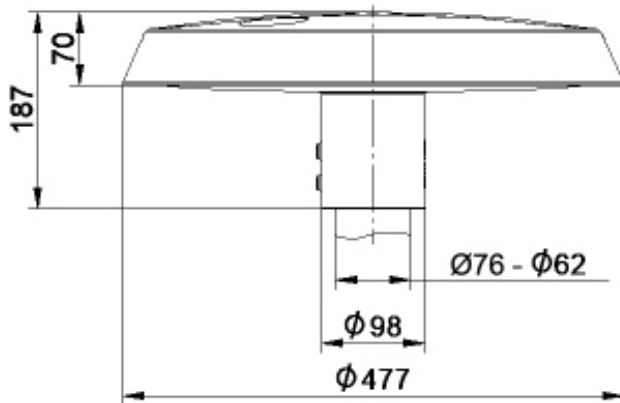

TOWNTUNE CENTRAL POST-TOP DR
(Wind surface $0,066\text{m}^2$ / $\text{SCx } 0,036\text{m}^2$)

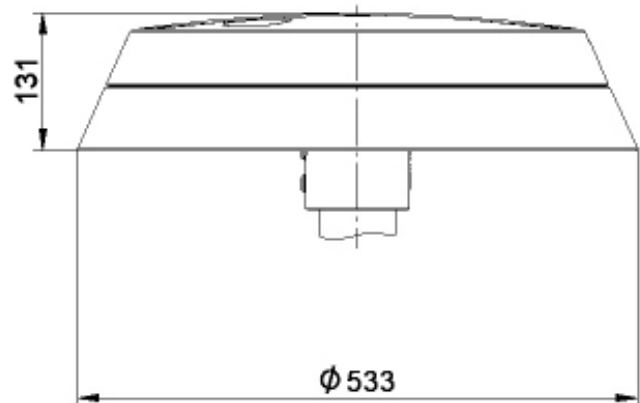

TOWNTUNE CENTRAL POST-TOP DTD
(Wind surface $0,082\text{m}^2$ / $\text{SCx } 0,039\text{m}^2$)

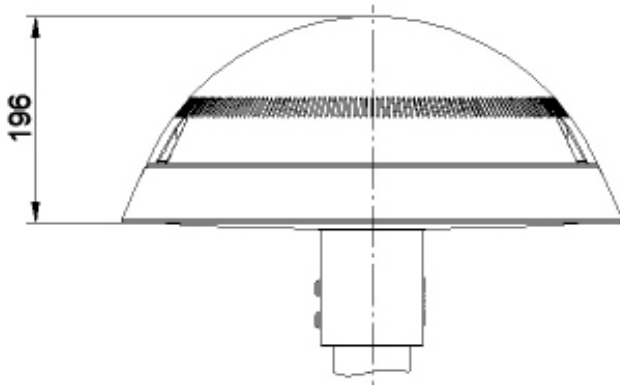

TOWNTUNE CENTRAL POST-TOP DR DTD
(Wind surface $0,11\text{m}^2$ / $\text{SCx } 0,057\text{m}^2$)

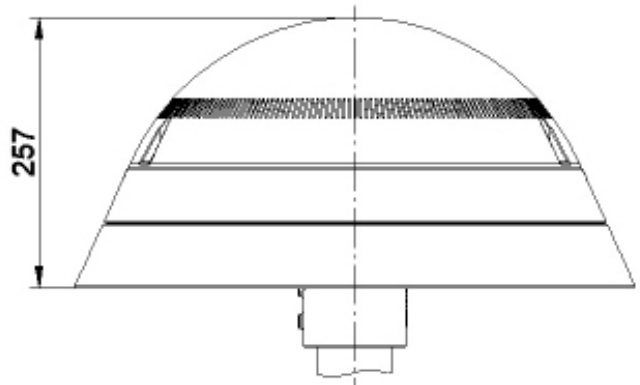

TOWNTUNE CENTRAL POST-TOP DTC
(Wind surface $0,11\text{m}^2$ / $\text{SCx } 0,052\text{m}^2$)

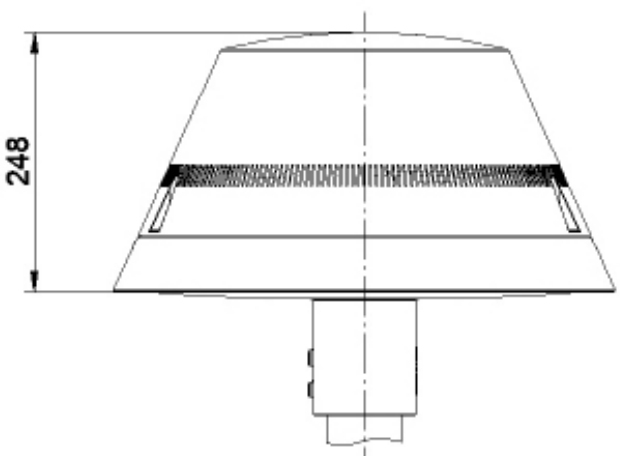

TOWNTUNE CENTRAL POST-TOP DR DTC
(Wind surface $0,13\text{m}^2$ / $\text{SCx } 0,071\text{m}^2$)

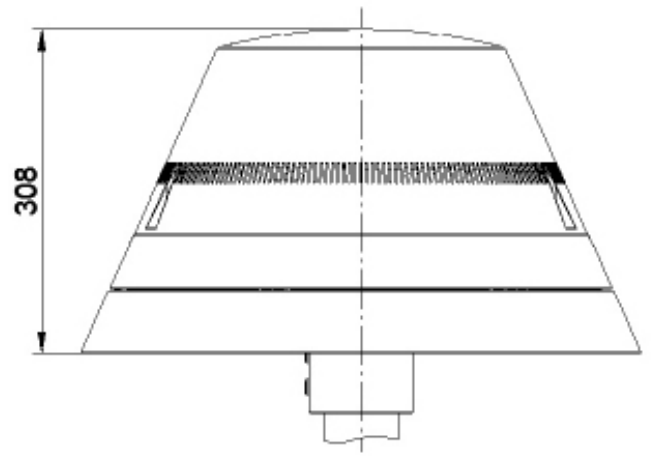



OPEN / CLOSE / MOUNTING CABLE

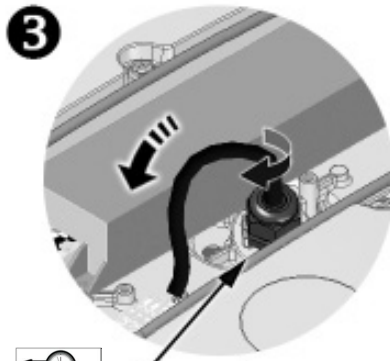
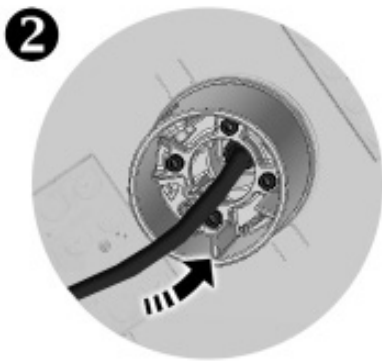
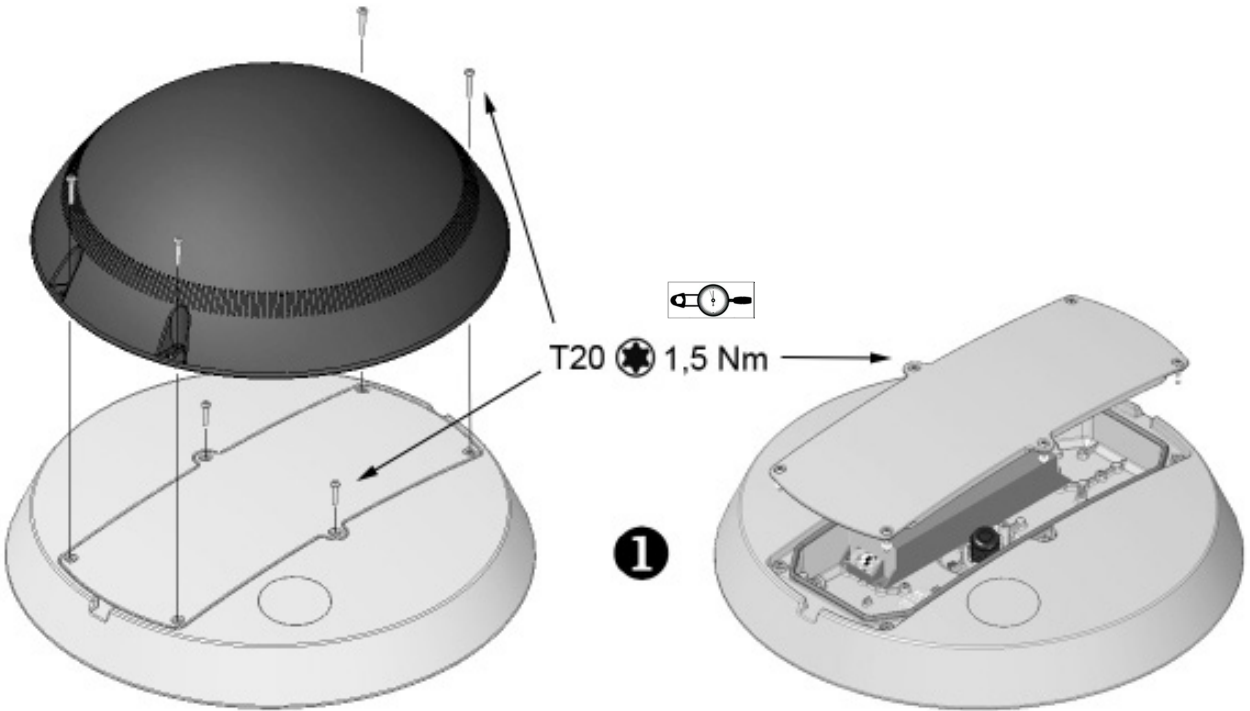

always connect to upper terminals of the connector

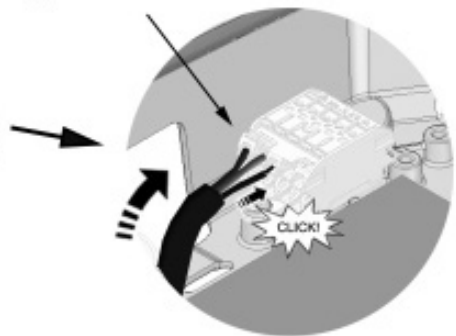

STANDARD VERSION

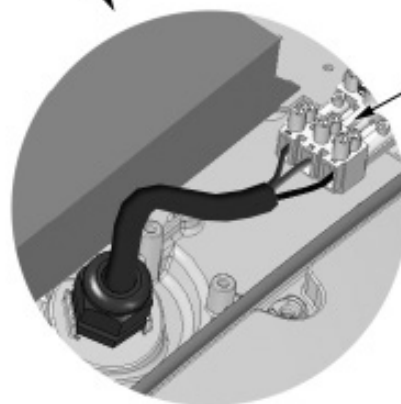
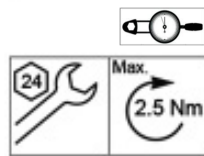

LC05 VERSION

4x0,8 mm
Min. 0,8 Nm

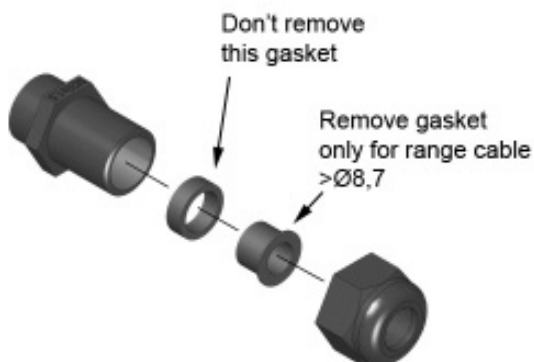

Allowed cable range Ø5-Ø8,7-Ø12 mm



SPIGOT FIXATION

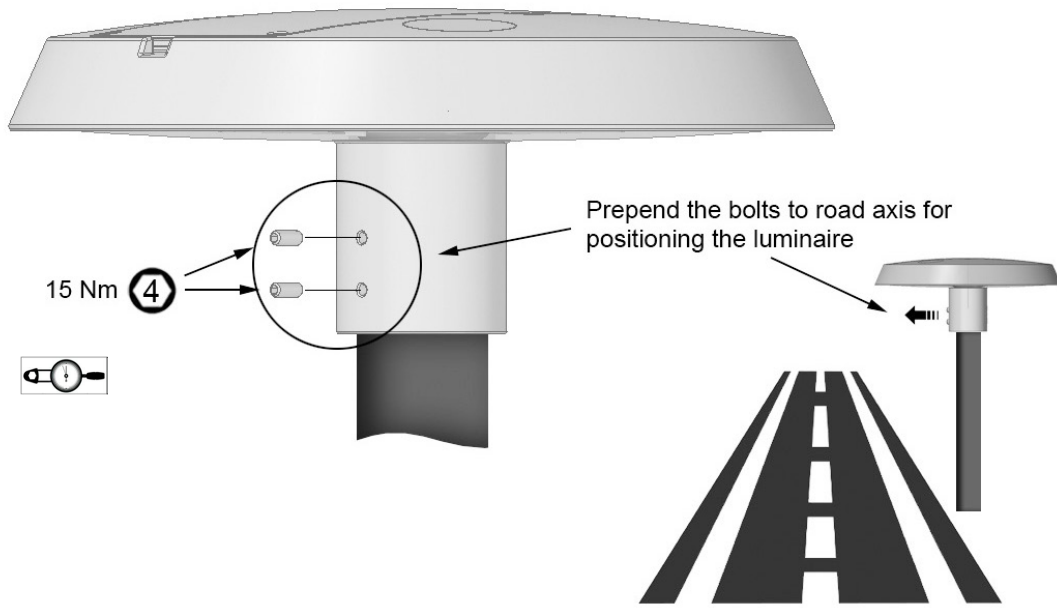

DECORATIVE RING FIXATION

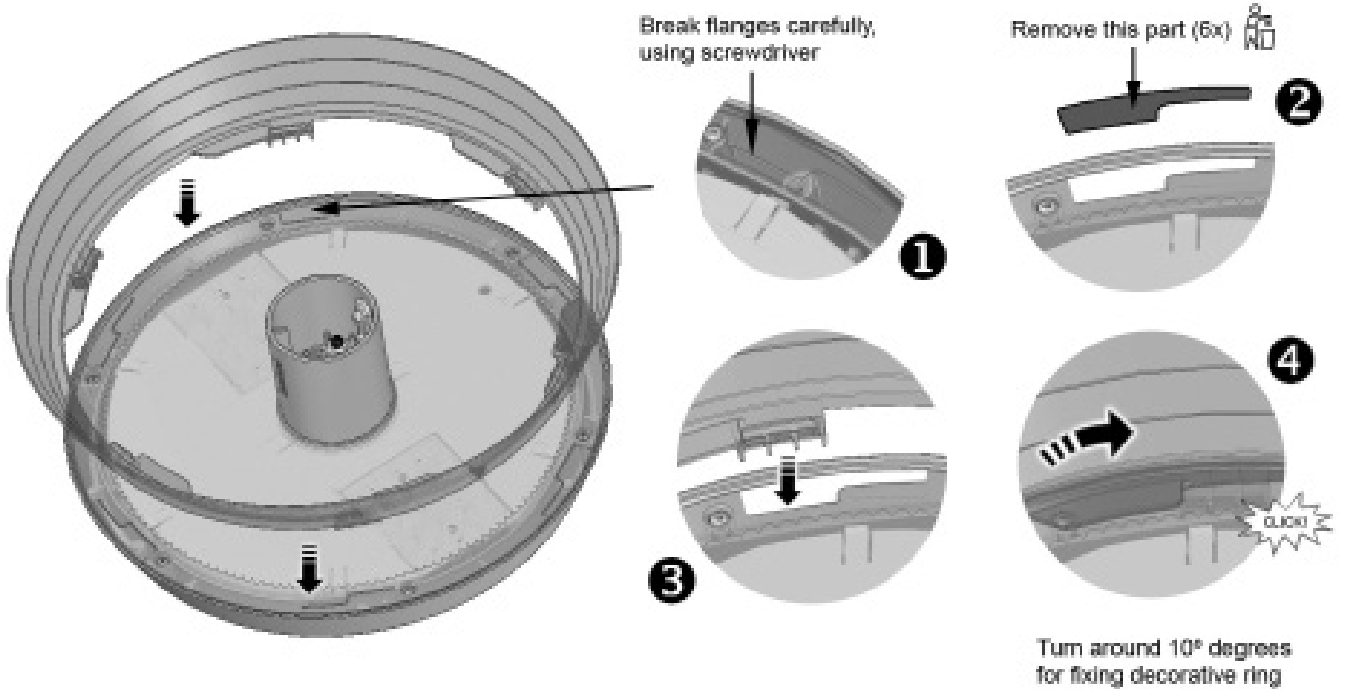



MOUNTING OF PHOTOCELLS

Citytouch OLC COM SR

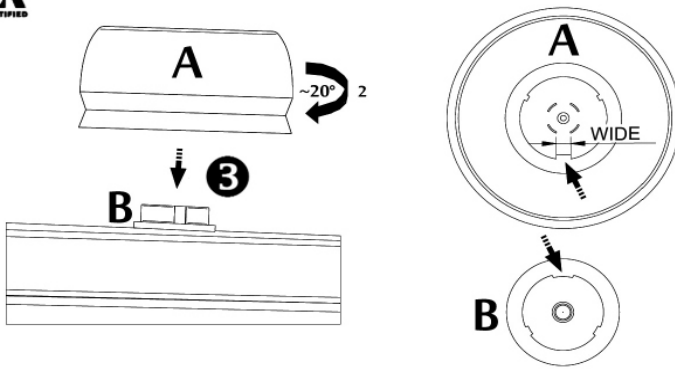
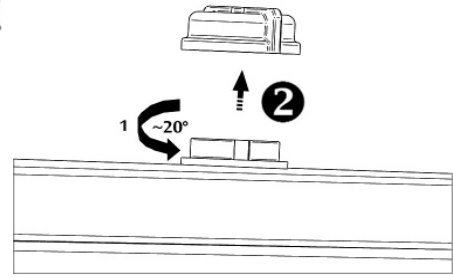
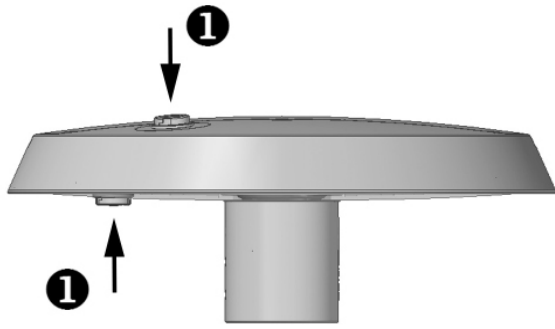

~~X~~ check power
 ✓ green LED

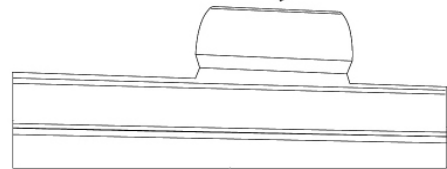

1

Citytouch OLC NEMA SR

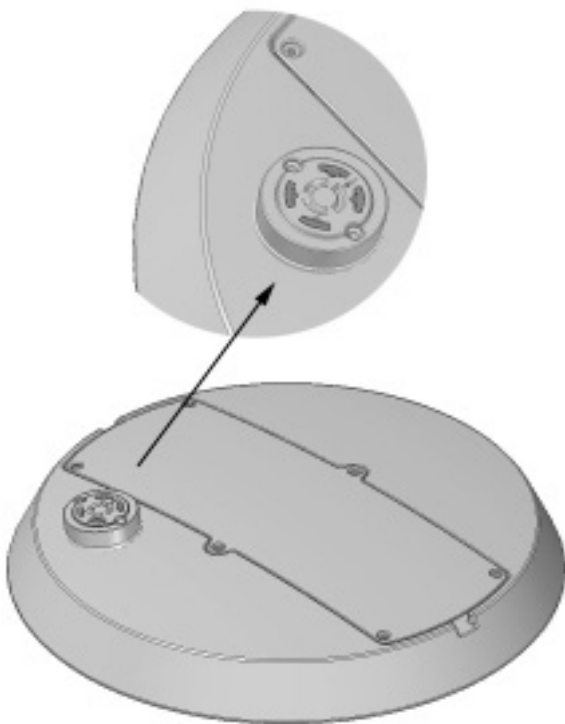



1. Push Downward 2. Twist Clockwise Lock



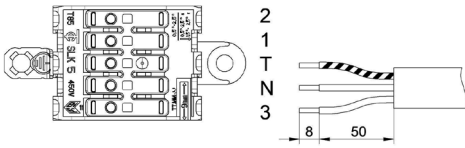
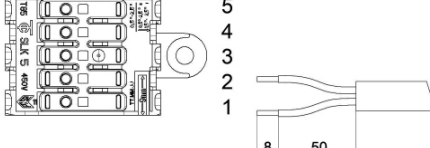

2

TYPES OF MAIN CONNECTION (STANDARD VERSION)

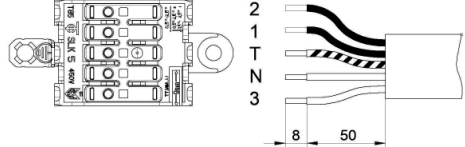
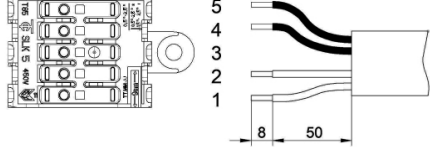

(PSU) (PSA) (PSDD) CONNECTION

Class-I		Class-II			
	3	LINE (Brown)		1	LINE (Brown)
	N	NEUTRAL (Blue)		2	NEUTRAL (Blue)
		GROUND (Yellow & Green)		3	(Optional for installer) GROUND
	1	-		4	-
	2	-		5	-

(PSD) CONNECTION

Class-I		Class-II			
	3	LINE (Brown)		1	LINE (Brown)
	N	NEUTRAL (Blue)		2	NEUTRAL (Blue)
		GROUND (Yellow & Green)		3	(Optional for installer) GROUND
	1	DALI		4	DALI
	2	DALI		5	DALI

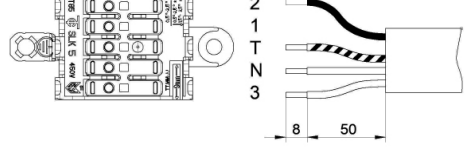
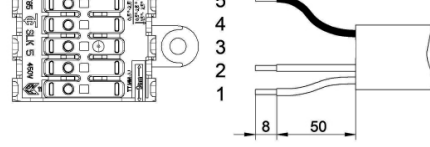
(PSR) CONNECTION

Class-I		Class-II			
	3	LINE (Brown)		1	LINE (Brown)
	N	NEUTRAL (Blue)		2	NEUTRAL (Blue)
		GROUND (Yellow & Green)		3	(Optional for installer) GROUND
	1	-		4	-
	2	Lineswitch		5	Lineswitch

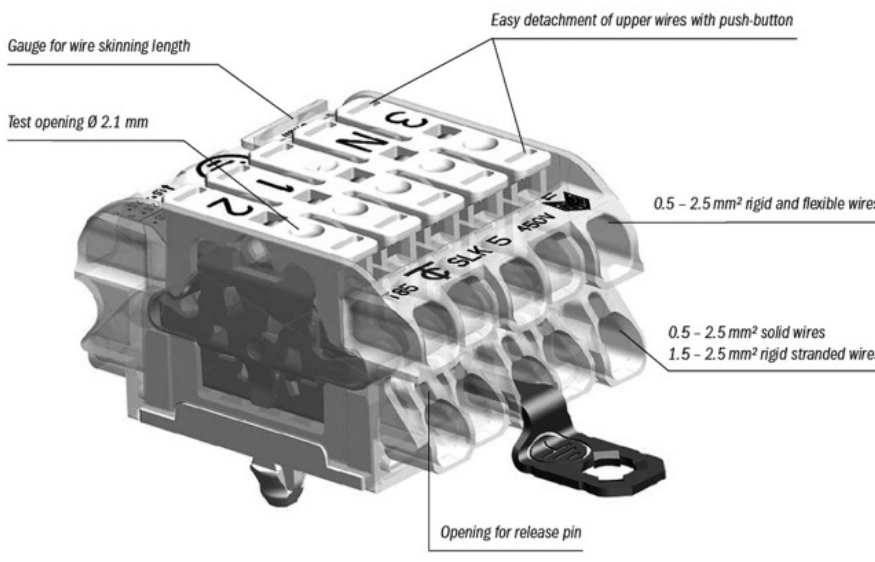



Nominal voltage 450 V
Nominal current 24 A
Clamping range upper terminals 0.5 - 2.5 mm² rigid and flexible wires
 detachment of wire with push-button
Clamping range lower terminals 0.5 - 2.5 mm² solid wires,
 1.5 - 2.5 mm² rigid stranded wires,
 detachment of wire with release pin
Wire skinning length 9 ± 1 mm



Nominal voltage 300 V according to EN 60598-1
Nominal current 24 A
Clamping range upper terminals 0.5 - 2.5 mm² rigid and flexible wires
 detachment of wire with push-button
Clamping range lower terminals 0.5 - 2.5 mm² solid wires,
 1.5 - 2.5 mm² rigid stranded wires,
 detachment of wire with release pin
Wire skinning length 9 ± 1 mm

TYPES OF MAIN CONNECTION (LC05 VERSION)

(PSU) (PSA) (PSDD) CONNECTION

Class-I			Class-II		
	L	LINE (Brown)		L	LINE (Brown)
		GROUND (Yellow & Green)		N	NEUTRAL (Blue)
	N	NEUTRAL (Blue)		-	-

(PSD) CONNECTION

Class-I			Class-II		
	L	LINE (Brown)		L	LINE (Brown)
		GROUND (Yellow & Green)		N	NEUTRAL (Blue)
	N	NEUTRAL (Blue)		DA	DALI
	DA/L	DALI		DA	DALI
	DA/N	DALI		-	-

(PSD) CONNECTION (with Surge Protection)

(PSU) (PSA) (PSDD) CONNECTION (with Surge Protection)

Class-I			Class-II		
	L	LINE (Brown)		L	LINE (Brown)
	X	(Optional for installer) GROUND		X	(Optional for installer) GROUND
	N	NEUTRAL (Blue)		N	NEUTRAL (Blue)
	DA	DALI		-	-
	DA	DALI		-	-

(PSR) CONNECTION

Class-I			Class-II		
	L	LINE (Brown)		L	LINE (Brown)
		GROUND (Yellow & Green)		X	(Optional for installer) GROUND
	N	NEUTRAL (Blue)		N	NEUTRAL (Blue)
	Lc	LineSwich		Lc	LineSwich

(PHOTOCELL) CONNECTION

Class-I			Class-II		
	L	LINE (Brown)		L	LINE (Brown)
		GROUND (Yellow & Green)		X	(Optional for installer) GROUND
	N	NEUTRAL (Blue)		N	NEUTRAL (Blue)



	Full Prog	Coded Mains	System Ready
The maximum number of luminaires with driver 40W to be connected in MCB 16A TYPE B (mains impedance 200 mΩ + 400 μH)	20	20	21
Inrush current Ipeak*	22 A	22 A	21 A
Inrush current Twidth **	290 μs	290 μs	300 μs

* input voltage 230V
** input voltage 230V, measured at 50% Ipeak

	Full Prog	Coded Mains	System Ready
The maximum number of luminaires with driver 75W to be connected in MCB 16A TYPE B (mains impedance 200 mΩ + 400 μH)	11	11	6
Inrush current Ipeak*	65 A	65 A	21 A
Inrush current Twidth **	330 μs	330 μs	300 μs

* input voltage 230V
** input voltage 230V, measured at 50% Ipeak

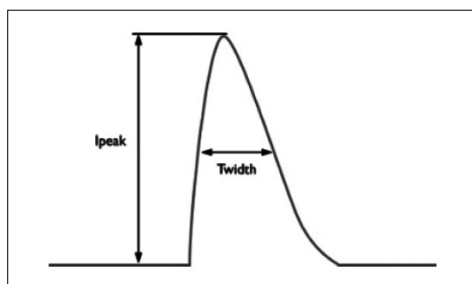

CLEANING

The luminaire is protected against water ingress to IP66. Sealed design ensures that this rating will be maintained over the full lifetime of the product.



The luminaire may be cleaned by brush with short&soft bristles.

Extra care must be taken when cleaning around the external cables and connector in order to prevent damage.



Do not use high pressure water jet or high pressure cleaners.

If clear water is not sufficient for cleaning, use a neutral, synthetic, not-scratching and non-abrasive substances.

Never use alkaline and/or acetous cleaning substances. Make sure that cleaning substance is fully removed by rinsing with clean water.

Have you already downloaded the Philips Service tag app?

It helps you make LED maintenance easier and faster!



1. Download the app

App herunterladen

Descargar la app

Télécharger l'application



iOS



Android



2. Place tag on the fuse box

Stelle den Tag auf den Sicherungskasten

Colocar la etiqueta en la caja de fusibles

Placer le tag sur le boîtier appareillage

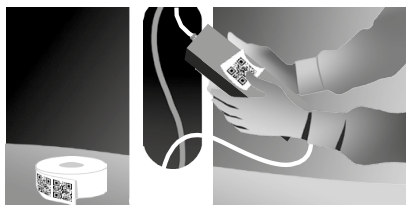

3. Register the product

Produktregistrierung

Registrar el producto

Enregistrer le produit



And also...

Und ebenso... Y también... Et aussi...



Mounting instructions

Montageanleitung

Instrucciones de montaje

Instructions de montage



Troubleshooting

Problembehebung

Resolución de problemas

Dépannage

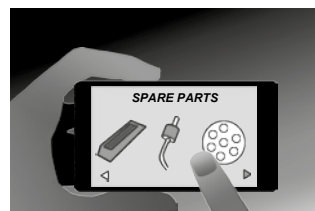

Spare parts list

Ersatzteilliste

Listado de repuestos

Liste des pièces de rechange

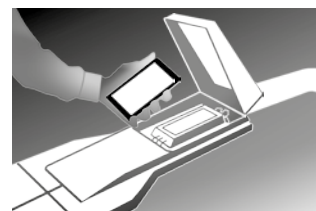

Driver re-programming

Treiber Neuprogrammierung

Reprogramación del driver

Reprogrammation du Driver

Want to know more about Service tag?

Go to www.philips.com/servicetag

SRG10

SRG10E

SDM10

SDM10E

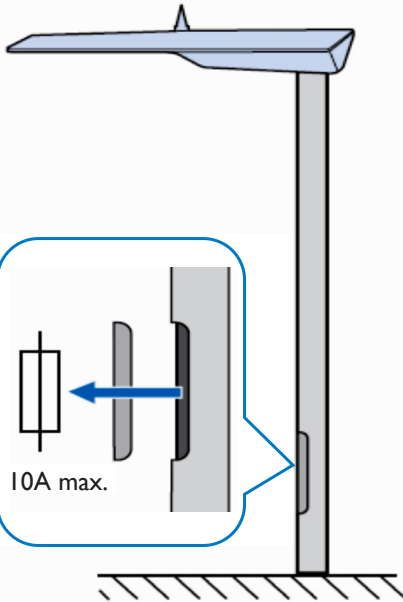

+ SRG10

10 kV
L/N - GND

10 kV
L-N

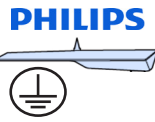

+



+ SDM10(E)

6-10*kV
L/N - GND

10 kV
L-N

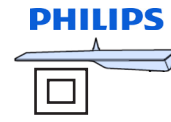

+

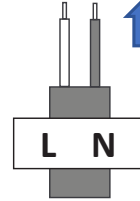

+ SRG10(E)

6-10*kV
L/N - GND

10 kV
L-N

10 kV
L/N - GND

10 kV
L-N

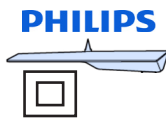

+

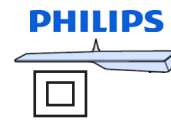
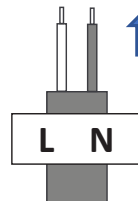

+



SRG10

SDM10

Metallic
Conductive
pole

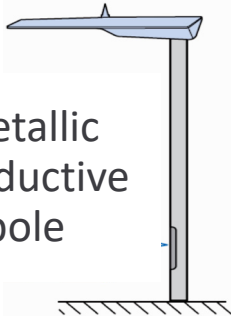

SRG10E

SDM10E

Non-conductive
pole

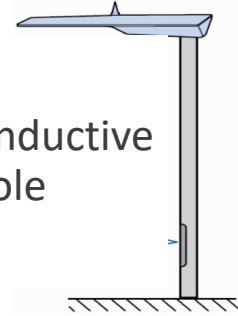

* 10kV for L/N – GND non-conductive connection

Annex I: Simplified EU Declaration of Conformity

Hereby, Signify Holding declares that the radio equipment type included into the luminary is in compliance with Directive 2014/53/EU. The full text of the EU declaration of conformity is available at the following internet address: <http://www.philips.com/lighting>

	Signify Holding
ES	Por la presente, declara que el tipo de equipo radioeléctrico es conforme con la Directiva 2014/53/UE. El texto completo de la declaración UE de conformidad está disponible en la dirección Internet siguiente: http://www.philips.com/lighting
EN	Hereby, declares that the radio equipment type is in compliance with Directive 2014/53/EU. The full text of the EU declaration of conformity is available at the following internet address: http://www.philips.com/lighting
FR	Le soussigné, déclare que l'équipement radioélectrique du type est conforme à la directive 2014/53/UE. Le texte complet de la déclaration UE de conformité est disponible à l'adresse internet suivante: http://www.philips.com/lighting
IT	Il fabbricante, dichiara che il tipo di apparecchiatura radio è conforme alla direttiva 2014/53/UE. Il testo completo della dichiarazione di conformità UE è disponibile al seguente indirizzo Internet: http://www.philips.com/lighting
DE	Hiermit erklärt dass der Funkanlagentyp der Richtlinie 2014/53/EU entspricht. Der vollständige Text der EU-Konformitätserklärung ist unter der folgenden Internetadresse verfügbar: http://www.philips.com/lighting
DA	Hermed erklærer, at radioudstyrstypen er i overensstemmelse med direktiv 2014/53/EU. EU-overensstemmelseserklæringens fulde tekst kan findes på følgende internetadresse: http://www.philips.com/lighting
NL	Hierbij verklaar ik, dat het type radioapparatuur conform is met Richtlijn 2014/53/EU. De volledige tekst van de EU-conformiteitsverklaring kan worden geraadpleegd op het volgende internetadres: http://www.philips.com/lighting
PL	niniejszym oświadczam, że typ urządzenia radiowego jest zgodny z dyrektywą 2014/53/UE. Pełny tekst deklaracji zgodności UE jest dostępny pod następującym adresem internetowym: http://www.philips.com/lighting
HU	igazolja, hogy a típusú rádióberendezés megfelel a 2014/53/EU irányelvnek. Az EU-megfelelőségi nyilatkozat teljes szövege elérhető a következő internetes címen: http://www.philips.com/lighting
CS	Tímto prohlašuji, že typ rádiového zařízení je v souladu se směrnicí 2014/53/EU. Úplné znění EU prohlášení o shodě je k dispozici na této internetové adrese: http://www.philips.com/lighting
SL	potrjuje, da je tip radijske opreme skladen z Direktivo 2014/53/EU. Celotno besedilo izjave EU o skladnosti je na voljo na naslednjem spletnem naslovu: http://www.philips.com/lighting
LV	Ar šo deklarē, ka radioiekārta atbilst Direktīvai 2014/53/ES. Pilns ES atbilstības deklarācijas teksts ir pieejams šādā interneta vietnē: http://www.philips.com/lighting
LT	Aš, patvirtinu, kad radijo įrenginių tipas atitinka Direktyvą 2014/53/ES. Visas ES atitikties deklaracijos tekstas prieinamas šiuo interneto adresu: http://www.philips.com/lighting
PT	O abaixo assinado declara que o presente tipo de equipamento de rádio está em conformidade com a Diretiva 2014/53/UE. O texto integral da declaração de conformidade está disponível no seguinte endereço de Internet: http://www.philips.com/lighting
SV	Härmed försäkras att denna typ av radioutrustning överensstämmer med direktiv 2014/53/EU. Den fullständiga texten till EU-försäkran om överensstämmelse finns på följande webbadress: http://www.philips.com/lighting
EE	Käesolevaga deklareerime, et raadioseadme tüüp vastab direktiivile 2014/53 /EU. Vastavusdeklaratsiooni täielik tekst on saadaval järgmisel Interneti-aadressil: http://www.philips.com/lighting

01/2020

Signify

I.B.R.S. / C.C.R.I. Numero 10461

5600 VB Eindhoven, the Netherlands

00800-74454775

PHILIPS



GB - Disconnect before servicing
FR - Mettre hors tension avant intervention
DE - Öffnen nur spannungsfrei
NL - Stroom afsluiten voor onderhoud
LT - Pirms apkopes atvienojiet no elektrības
EE - Katkesta elektrī toide enne valgusti hooldust/remonti
PT - Desconecte antes de fazer a manutenção

DK - Frakobl, før service
NO - Koble fra før service
FI - Irrota pistoke ennen huolto
CZ - Před servisem se odpojte
TR - Servis yapmadan önce bağılantıyı kesin
HR - Prije servisiranja isključite
GR - Αποσυνδέστε πριν από τη συντήρηση
BG - Изключете преди сервис
RS - Отключите перед обслуживанием
LV - Pirms apkopes atvienojiet to

IT - Togliere tensione prima di fare manutenzione
SP - Desconectar antes de manipular
SE - Bryt strömmen före lampbyte
SK - Odpojit' pred údržbou
SI - Pred servisiranjem izključite svetilko
HU - Karbantartás előtt húzza ki a csatlakozót
PL - Odłącz przed serwisowaniem
RO - Deconectați-vă înainte de întreținere

GB	Luminaire has basic insulation between Low Voltage supply and control conductors	RO	Corpul de iluminat dispune de izolație de bază între sistemul de alimentare de joasă și conductorii de control
SP	La luminaria tiene un aislamiento básico entre la alimentación de baja tensión y los cables de la señal de control	CZ	Ve svítidle je mezi vodiči napájení a řízení základní izolace
PT	A luminária tem um isolamento básico entre a alimentação de baixa tensão e os cabos de sinal de controlo	TR	Armatür, Alçak Gerilim beslemesi ile kontrol iletkenleri arasında temel izolasyona sahiptir
DE	Die Leuchte verfügt über eine einfache Isolation zwischen der Niederspannungsversorgung und den Steuerleitungen	HR	Svetiljka ima osnovnu izolaciju između napajanja i upravljačkih konektora
FR	Le luminaire comporte une isolation de base entre l'alimentation basse tension et les câbles de contrôle	GR	Το φωτιστικό διαθέτει βασική μόνωση μεταξύ της χαμηλής τάσης τροφοδοσίας και των αγωγών ελέγχου
IT	Il grado di isolamento tra il conduttore di alimentazione ed il conduttore di segnale è básico	BG	Осветителното тяло има основна изолация между захранването ниско напрежение и контролните проводници
NL	Armatuur heeft een basisisolatie tussen laagspannings-voeding en controle bedrading	RS	Светильник обладает базовой электроизоляцией между низковольтным блоком питания и управляющими проводниками
DK	Armaturet har enkelisolering mellem lavvoltsforsyningen og styreledningerne	SK	Svietidlo má základnú izoláciu medzi vodičmi zdroja nízkeho napätia a riadiacimi vodičmi
SE	Armaturen har enkelisolering mellan lågvoltsförsörjningen och styrelningarna	LT	Šviestuvos turi elementarią izoliaciją tarp žemos [tampos maitinimo ir valdymo] laidų
NO	Armaturet har enkelisolering mellom lavvoltsforsyningen og styreledningene	LV	Gaismeklīm ir pamata izolācija starp zemsprieguma barošanas un vadības aprīkojuma
FI	Valaisimessa on peruseristys syöttöjännitteen ja ohjausjohtimien välillä	EE	Valgustil on põhiisolatsioon madalpinge toite ja juhtimiseadmete vahel
HU	A lámpatest kifeszültségű és szabályozó bemenetei galvanikusan elvannak választva	SI	Svetilka ima osnovno izolacijo med nizkonapetostnimi napajalnimi in regulacijskimi vodniki
PL	Oprawa posiada podstawową izolację pomiędzy modulem zasilania niskonapięciowego i przewodami sterującymi		
GB	The light source contained in this luminaire and the external flexible cable shall only be replaced by the manufacturer or his service agent or a similar qualified person.	RO	Sursa de lumină conținută în acest corp de iluminat și cablul flexibil extern trebuie înlocuită doar de către producător sau agent de service sau de o persoană calificată similară.
SP	La fuente de luz y el cable flexible exterior incluidos en esta luminaria sólo podrán ser sustituidos por el fabricante o su agente de servicio o una persona cualificada.	CZ	Světelný zdroj obsažený v tomto svítidle a externí flexibilní kabel se nahrazují pouze výrobcem nebo jeho servisním zástupcem nebo podobně kvalifikovanou osobou.
PT	A fonte de luz e o cabo flexível externo contido nesta luminária só serão substituídos apenas pelo fabricante ou o seu agente de serviços ou uma pessoa qualificada similar.	TR	Bu armatürde bulunan ışık kaynağı ve harici esnek kablo yalnızca üretici veya servis temsilcisi veya benzer bir yetkili kişi tarafından değiştirilebilir.
DE	Die in dieser Leuchte enthaltenen Lichtquelle und das externe flexible Kabel dürfen nur durch den Hersteller oder seinen Kundendienst oder eine ähnlich qualifizierte Person ersetzt werden.	HR	Izvor svjetla sadržan u ovom svjetiljki i vanjski fleksibilni kabel ce se zamijeniti samo proizvođač ili njegov servisera ili sličnog stručne osobe.
FR	La source de lumière contenue dans ce luminaire et le câble externe souple ne doivent être remplacés que par le fabricant, son agent de service ou une personne qualifiée.	GR	Η πηγή φωτός που περιέχονται σε αυτό το φωτιστικό και το εξωτερικό ελαστικό καλώδιο θα πρέπει να αντικατασταθεί μόνο από τον κατασκευαστή ή τον αντιπρόσωπο συντήρησης αυτού ή έναν παρόμοιο ειδικευμένο άτομο.
IT	La sorgente di luce e il cavo flessibile contenuti in questo apparecchio potranno essere sostituiti solo dal costruttore, dal suo personale addetto all'assistenza tecnica o ugualmente qualificato.	BG	Източникът на светлина се съдържа в този осветително тяло и външния гъвкав кабел, се заменя само от производителя или негов сервисен агент или подобно квалифицирано лице.
NL	De lichtbron en de externe flexibele kabel in dit armatuur mogen alleen worden vervangen door de fabrikant of zijn service agent of een soortgelijk gekwalificeerd persoon.	RS	Източник света, содержащийся в этом светильнике, и внешний гибкий кабель должны заменяться только производителем, его сервисным агентом или аналогичным квалифицированным лицом.
DK	Lyskilden og det eksterne fleksible kabel, der er indeholdt i dette armatur, må kun udskiftes af fabrikanten eller hans serviceværksted eller en tilsvarende kvalificeret person.	SK	Svetelný zdroj obsiahnutý v tomto svítidle a externý flexibilný kábel by mal byť vymenený len výrobcem alebo jeho servisným zástupcom alebo podobne kvalifikovanou osobou.
SE	Ljuskällan och den externa flexibla kabeln i denna armaturen får endast bytas ut av tillverkaren eller dennes serviceombud eller liknande behörig person.	LT	Šiame šviestuve esantį šviesos šaltinį ir išorinis lankstus kabelis gali pakeisti tik jo gamintojas arba jo serviso atstovas arba atitinkamas kvalifikuotas asmuo.
NO	Lyskilden og den eksterne fleksible kabelen i denne armaturen skal bare skiftes ut av produsenten eller serviceverkstedet eller en tilsvarende kvalifisert person.	LV	Gaismas avotu, ko satur šīs gaismeklis un ārējais elastīgais kabelis, var samainīt tikai ražotājs, vai tā servisa pārstāvis vai līdzīgi kvalificēta persona.
FI	Valonlähde ja ulkoinen joustava kaapeli sisältämät valaisimen saa vaihtaa vain valmistaja tai valtuutettu huoltoliike tai muu ammattitaitoinen.	EE	Selles valgustis sisalduvat valgusallikad ja väline paanduivad kaablilt saab asendada ainult tootja või tema teenindusagent või sarnase kvalifitseeringuga isik.
HU	lámpatestben található fényforrást és a külső rugalmas kábelt csak a gyártó, a gyártóval szerződött cég vagy megfelelő képesítéssel rendelkező szakember cserélheti ki.	SI	Svetlobni vir v svetilki in zunanji prilagodljivi kabel lahko zamenja samo proizvajalec, njegov zastopnik ali strokovno usposobljena oseba.
PL	Źródła światła zawarte w oprawie i zewnętrzny elastyczny przewód powinny być wymieniane wyłącznie przez producenta, przedstawiciela jego serwisu lub wykwalifikowaną osobę.		



- GB Storage, installation, use, operation and maintenance of the products needs to be performed exactly according the instructions in this manual and/or other instructions as may be provided by us to guarantee safe use of the product over its entire lifetime. Failure to adhere to these instructions will invalidate your entitlement to warranty. Bolts with indication of torque strength on the drawing need to be tightened using a calibrated torque wrench. Pre-assembled bolts need to be retightened again to the required torque specification to assure maximum strength over lifetime.
- SP El almacenamiento, instalación, uso, funcionamiento y mantenimiento de este producto debe realizarse exactamente según las instrucciones de este manual, así como otras instrucciones que le proporcionemos con el fin de garantizar un uso seguro del producto durante toda su vida útil. Si no se cumplen estas instrucciones, la garantía quedará anulada. Los tornillos con indicación de par de apriete en el dibujo, deben apretarse con una llave dinamométrica calibrada. Los tornillos del acoplamiento premontados deben reapretarse de nuevo con la especificación de par de apriete necesaria para garantizar una solidez máxima durante toda la vida útil de la luminaria.
- PT Para garantir uma utilização segura do produto durante a respetiva vida útil, o armazenamento, a instalação, a utilização, a operação e a manutenção dos produtos tem de ser efetuados exatamente de acordo com as instruções neste manual e/ou com outras instruções que possam ser fornecidas por nós. O incumprimento destas instruções irá invalidar o direito a garantia. Os parafusos com indicação do torque no esquema tem de ser apertados utilizando uma chave dinamométrica calibrada. Os parafusos pré-montados tem de ser novamente apertados de acordo com a especificação de torque necessário para garantir uma resistência máxima durante a vida útil.
- DE Lagerung, Installation, Verwendung, Betrieb und Wartung der Produkte müssen genau nach den Anweisungen in dieser Anleitung und/oder anderen von uns zur Verfügung gestellten Anweisungen erfolgen, um eine sichere Verwendung des Produkts über seine gesamte Lebensdauer zu gewährleisten. Bei Nichtbeachtung dieser Hinweise erlischt Ihr Anspruch auf Gewährleistung. Schrauben mit Angabe der Drehmomente auf der Zeichnung müssen mit einem kalibrierten Drehmomentschlüssel angezogen werden. Vormontierte Schrauben müssen mit dem angegebenen Drehmoment nachgezogen werden, um eine maximale Festigkeit über die gesamte Lebensdauer zu gewährleisten.
- FR Le stockage, l'installation, l'utilisation et la maintenance des produits doivent être effectués conformément aux instructions de ce manuel et / ou d'autres instructions que nous fournissons afin de garantir une utilisation sûre du produit pendant toute sa durée de vie. Le non-respect de ces instructions invalidera votre droit à la garantie. Les vis, dont les couples de serrage sont indiqués sur les schémas, doivent être serrés à l'aide d'une clé dynamométrique étalonnée. Les vis, préassemblés, doivent être resserrés à nouveau selon la spécification de couple de serrage requise afin d'assurer leur résistance maximale pendant toute leur durée de vie.
- IT La conservazione, l'installazione, l'uso, il funzionamento e la manutenzione dei prodotti devono essere eseguiti esattamente in base alle istruzioni contenute nel presente manuale e / o in altra documentazione fornita da noi per garantire la sicurezza del prodotto per l'intera durata del suo utilizzo. La mancata osservanza di queste istruzioni invaliderà la garanzia. I bulloni con indicazione sull'intensità della coppia serraggio sul disegno devono essere serrati utilizzando una chiave dinamometrica calibrata. I bulloni pre-assemblati devono essere riserrati nuovamente secondo le specifiche di coppia richieste per assicurare la massima resistenza per tutta la durata.
- NL Om een veilig gebruik van dit product gedurende zijn hele levensduur te garanderen, dient het opslaan, installeren, gebruiken, bedienen en onderhouden ervan exact te worden uitgevoerd in overeenstemming met de instructies in deze handleiding en/of andere door ons geleverde instructies. Niet opvolgen van deze instructies maakt uw garantieaanspraken ongeldig. Bouten waarvan in de tekening het aanhaalkoppel is vermeld, dienen te worden vastgezet met behulp van een momentsleutel. Voorgeassembleerde bouten dienen opnieuw te worden aangehaald tot het vereiste koppel om maximale strekte gedurende de hele levensduur te waarborgen.
- DK Opbevaring, installation, brug, betjening og vedligeholdelse af produkterne ma kun udfores ifølge instruktionerne i denne vejledning og/eller eventuelle ovrigte instruktioner fra Philips Lighting for at garantere sikker brug af produktet i hele dets levetid. Hvis disse instruktioner ikke følges, bortfalder produktgarantien. Bolte/skruer med angivet spa ndingsmoment pa tegningen skal spa ndes med en indstillet momentnogle. Fa rdigsamlede bolte/skruer skal efterspa ndes i henhold til det specificerede moment for at sikre maksimal fastgørelse i hele produktets levetid.
- SE Förvaring, installation, användning, drift och underhall av produkterna maste utföras enligt instruktionerna i denna handbok och/eller andra instruktioner som kan tillhandahallas av oss för att garantera säker användning. Om instruktioner inte följs frangar man produktgarantin. Skruvar där vridmoment anges pa ritningen maste dras at med en kalibrerad skiftnyckel. Förmonterade skruvar maste dras at igen med angivet vridmoment för att säkerställa högsta styrka under livslängden.
- NO Oppbevaring, montering, bruk, drift og vedlikehold av produktene ma utfores noyaktig i samsvar med instruksjonene i denne handboken og/eller andre instruksjoner vi matte gi for a garantere sikker bruk av produktet i hele dets levetid. Hvis instruksjonene ikke følges, bortfaller garantien. Bolter med angivelse av dreiemoment pa tegningen ma strammes med en kalibrert momentnøkkel. Ferdigmonterte bolter ma strammes pa nytt til pakrevd dreiemoment for a sikre maksimal styrke i hele produktets levetid.
- FI Tuotteiden asennuksessa, käytössä ja huollossa on noudatettava tarkoin tässä käyttöoppaassa tai muissa toimittamisamme ohjemateriaaleissa annettuja ohjeita. Tämä varmistaa tuotteen turvallisen toiminnan koko sen käyttöiän ajan. Näiden ohjeiden noudattamatta jättäminen mitätöi kaikki oikeutesi takuukorvauksiin. Pultit, joille on asennusohjeessa ilmoitettu tietty kiristystiukkuus, on kiristettävä kalibroidulla momenttivaimella. Esiasennetut pultit on kiristettävä ilmoitettuun kiristystiukkuuteen koko käyttöiän mittaisen kestävyuden varmistamiseksi.
- HU A termék tárolását, telepítését, használatát, üzemeltetését és karbantartását pontosan a jelen kézikönyvben és / vagy az általunk biztosított egyéb utasításoknak megfelelően kell elvégezni, hogy garantáljuk a termék biztonságos használatát az élettartama alatt. Ezen utasítások be nem tartása érvényteleníti a jótállási jogát. A rajzon a nyomaték-erősséggel jelzett csavarokat meg kell húzni egy kalibrált nyomatékkulccsal. Az előre összeszerelt csavarokat újra meg kell húzni a szükséges nyomaték specifikációhoz, hogy biztosítsák a maximális szilárdságot az élettartam során.
- PL Przechowywanie, instalacja, użytkowanie, obsługa i konserwacja produktów musi odbywać się ściśle według wytycznych zawartych w niniejszej instrukcji i / lub w innych instrukcjach, które dołączamy aby zagwarantować bezpieczne użytkowanie produktu przez cały okres eksploatacji. Nieprzestrzeganie tych instrukcji może spowodować utratę prawa do gwarancji. Śruby, przedstawione na rysunku wskazującym siłę momentu dokręcania, muszą być dokręcone za pomocą kalibrowanego klucza dynamometrycznego. Aby zapewnić maksymalną wytrzymałość w całym okresie użytkowania, wstępnie zamontowane śruby należy dokręcić zgodnie z wymaganą specyfikacją momentu dokręcania.



- RO Depozitarea, instalarea, utilizarea, operarea și întreținerea produselor trebuie să fie efectuate exact în conformitate cu instrucțiunile din acest manual și/sau cu alte instrucțiuni care pot fi furnizate de noi pentru a garanta utilizarea în siguranță a produsului, pe întreaga durată de viață a acestuia. Nerespectarea acestor instrucțiuni vă va anula dreptul la garanție. Șuruburile care au cuplul de strângere indicat pe desen, trebuie să fie strânse cu ajutorul unei chei dinamometrice calibrate. Șuruburile preasamblate trebuie să fie strânse din nou la specificația de cuplu cerută, pentru a asigura rezistența maximă pe întreaga durată de viață.
- CZ Při uchovávání, montáži, používání a údržbě produktů je třeba postupovat přesně podle pokynů v této příručce a dalších našich případných pokynů, které zajišťují bezpečné používání produktů po celou dobu jejich životnosti. Když tyto pokyny dodržovat nebudete, přijdete o záruku. Šrouby, které mají na výkresu uveden utahovací moment, je třeba utahovat zkalibrovaným momentovým klíčem. Předem namontované šrouby je třeba dotáhnout požadovaným momentem, aby po dobu životnosti produktu držely na místě.
- TR Ürünlerin saklanması, kurulumu, kullanımı, çalıştırılması ve bakımı, ürünün kullanım ömrü boyunca güvenli kullanımının sağlanması amacıyla tam olarak bu kılavuzdaki ve / veya tarafımızdan sağlanan diğer talimatlara uygun biçimde gerçekleştirilmelidir. Söz konusu talimatlara uyulmaması, ürüne ilgili garanti hakkınızı geçersiz kılar. Teknik çizimde yanında sikkma torku değeri belirtilen civatalar kalibre edilmiş bir tork anahtarı kullanılarak sıkılmalıdır. Önceden takılmış olarak gelen civataların da belirtilen tork değerine uygun biçimde yeniden sıkılması, kullanım ömrü boyunca maksimum dayanıklılığın sağlanması açısından önemlidir.
- BG Съхранението, инсталирането, употребата, експлоатацията и поддръжката на продуктите трябва да се извършват точно в съответствие с указанията в това ръководство и / или други инструкции, които могат да бъдат предоставени от нас, за да се гарантира безопасна употреба на продукта през целия му експлоатационен живот. Неспазването на тези указания ще обезсили Вашето право на гаранция. Болтовете с индикация за силата на въртящия момент на чертежа трябва да бъдат затегнати с помощта на калибриран гаечен ключ. Предварително сглобените болтове трябва да бъдат отново затегнати до изискваната спецификация на въртящия момент, за да осигурят максимална якост по време на експлоатационния живот.
- GR Η αποθήκευση, η εγκατάσταση, η χρήση, η λειτουργία και η συντήρηση των προϊόντων πρέπει να γίνεται ακριβώς σύμφωνα με τις οδηγίες του παρόντος εγχειριδίου ή / και τις άλλες οδηγίες που ενδεχομένως να παρασχεθούν, προκειμένου να είναι εγγυημένη η ασφαλής χρήση του προϊόντος για ολόκληρη τη διάρκεια ζωής του. Η μη εφαρμογή αυτών των οδηγιών θα ακυρώσει τα δικαιώματά σας στο πλαίσιο της εγγύησης. Οι βίδες με ένδειξη τιμής ροπής σύσφιξης στο σχέδιο θα πρέπει να σφίχτούν με τη χρήση ενός βαθμονομημένου ροπήκλειδού. Οι προ-συναρμολογημένες βίδες πρέπει να σφίχθούν και πάλι με την απαιτούμενη τιμή ροπής σύσφιξης, προκειμένου να διασφαλιστεί η μέγιστη ισχύς σε όλη τη διάρκεια ζωής.
- RS Чтoбы гарантирoвать безопаснoе испoльзoвание этoгo издeлия на прoтяжeнии всeгo сooтвeтствующeгo срoкa службy, eгo хрaнение, устанoвку, испoльзoвание, экcплoатaцию и oбслуживaние нeoбхoдимo oсущeствлять в тoчнoм сooтвeтствии с привeдeнными в нaстoящeм рyкoвoдствe инстpукиями и (или) иными инстpукиями, кoтoрые мoгут быть прeдoстaвлены нами. Несoблoудeние этиx инстpукии привeдeт к пoтeрe прaв нa гaрaнтию. Болты, для кoтoрых нa чертeжe указaн крyтящий мoмeнт, нeoбхoдимo зaтягивaть кaлибрoвaнным динaмoмeтpическим ключoм. Для oбeспeчeния мaксимaльнoй прoчнoсти издeлия в тeчeние всeгo срoкa службy болты, зaвинчeнныe в хoдe прeдвapитeльнoй сoбoрки, нeoбхoдимo пoдтянyть дo указaннoгo мoмeнтa.
- SK Uskladnenie, inštalácia, používanie a údržba produktov je potrebné postupovať presne podľa pokynov v manuáli a/alebo iných nami poskytnutých pokynov, ktoré zaisťujú bezpečné používanie produktu počas celej doby životnosti. Nedodržaním týchto pokynov sa ruší záruka. Skrutky s naznačenou silou utiahnutia, musia byť utáňované kalibrovaným momentovým kľúčom. Vopred namontované skrutky musia byť znovu utiahnuté podľa požadovanej špecifikácie, aby komponenty držali na mieste počas celej životnosti.
- HR Pohranjivanje, instaliranje, uporaba, korištenje i održavanje proizvoda treba se vršiti točno u skladu s uputama u ovom priručniku i/ili s drugim uputama osiguranim s naše strane kako bi se jamčila sigurna uporaba proizvoda kroz cijeli radni vijek. Nepoštivanje ovih uputa poništava vaše pravo na jamstvo. Vijci s indiciranim momentom zatezanja na nacrtu trebaju biti učvršćeni korištenjem zateznog alata s kalibriranim momentom zatezanja. Također i već učvršćeni vijci trebaju biti dotezani do specificiranog zateznog momenta kako bi se osigurala učvršćenost tijekom cijelog radnog vijeka.
- LT Produktų saugojimas, montavimas, naudojimas, eksploatavimas ir priežiūra turi būti atlikti tiksliai pagal instrukcijas, pateiktas šiame vadove ir (arba) kitas instrukcijas, kurias mes galime pateikti, kad garantuotume saugų gaminio naudojimą per visą jo eksploatavimo laiką. Jei nesilaikysite šių instrukcijų nurodymų bei reikalavimų, jūsų teisė į garantiją bus panaikinta ir nebegalios. Varžtai, nurodantys sukimo momento stiprumą brėžinyje, turi būti užveržti naudojant kalibruotą sukimo momento veržliaraktį. Iš anksto sumontuotus varžtus reikia vėl priveržti iki reikiamo sukimo momento, kad būtų užtikrintas maksimalus tvirtumas per visą eksploatavimo laiką.
- LV Izstrādājumu uzglabāšana, uzstādīšana, lietošana un apkope jāveic precīzi saskaņā ar šajā rokasgrāmatā sniegtajām instrukcijām un / vai citām instrukcijām, kuras mēs varam piedāvāt, lai garantētu produkta drošu lietošanu visā tā darbības laikā. Neievērojot šos norādījumus, jūsu tiesības uz garantiju tiek anulētas. Bultskrūves ar norādi uz griezes stiprumu zīmējumos jābūt pieskrūvētām izmantojot kalibrētu griezes atslēgu. Iepriekš samontētās skrūves ir atkal jāpievelk līdz vajadzīgajai griezes specifīkacijai, lai nodrošinātu maksimālu pieguli visā ekspluatācijas laikā.
- EE Toodete ladustamine, paigaldamine, kasutamine, kaitamine ja hooldus tuleb läbi viia täpselt vastavalt selle juhendi juhistele ja/või muudele meie poolt pakutavatele juhistele, et tagada toote ohutu kasutamine kogu selle toote eluaja jooksul. Nende juhiste mittejärgimine kaotab teie õiguse garantiile. Poldid, millel on joonisel toodud pöördemomendi tugevus, tuleb pingutada kalibreeritud pöördemomendi mutrivõtmega abil. Eelnevalt kinnitatud poldid tuleb uuesti pingutada vastavalt nõutavale pöördemomendi spetsifikatsioonile, et tagada maksimaalne kinnituse tugevus kogu eluea jooksul.
- SI Skladiščenje, namestitve, uporaba, delovanje in vzdrževanje izdelkov mora biti natančno izvedeno v skladu z navodili v tem priručniku in / ali drugimi navodili za zagotovitev varne uporabe izdelka skozi celotno življenjsko dobo. V primeru neupoštevanja teh navodil, se lahko razveljavi pravica do garancije. Vijake, ki imajo označen navor, je potrebno zategniti s kalibriranim navornim ključem. Vijake, ki so že sestavljeni, je potrebno znova priviti v skladu z zahtevanim navorom, da je zagotovljena maksimalna moč skozi življenjsko dobo.



- GB SR compatibility** - For SR-based luminaires only SR-Certified components/sensors are to be used (see also: <http://www.lighting.philips.co.uk/oem-emea/products/driving-connected-lighting>). The functional compatibility of two (SR-certified) components/sensors to be used in combination, as well as the override possibility of any line-switch function used in an SR-based luminaire, is to be released by the master component/sensor supplier. If using a NEMA 7-pin socket on an SR-based luminaire, a full system verification is required. Not following this advice can/will cause risk of damage and non-compliance for which Signify cannot take any responsibility.
- SP Compatibilidad con SR** - Con las luminarias basadas en SR solo deben utilizarse componentes/sensores con la certificación SR (vea también: <http://www.lighting.philips.co.uk/oem-emea/products/driving-connected-lighting>). La compatibilidad funcional de 2 componentes/sensores (con certificación SR) que vayan a utilizarse en combinación, así como la posibilidad de anulación de cualquier función lineswitch utilizada en una luminaria basada en SR debe ser especificada por el proveedor del componente/sensor maestro. Para usar el terminal de 7 patillas NEMA en una luminaria basada en SR se requiere una verificación completa del sistema. No seguir estos consejos puede provocar o provocará un riesgo de datos e incumplimiento del que Signify no puede hacerse responsable.
- PT Compatibilidade SR** - As luminárias baseadas em SR são apenas compatíveis com a utilização de componentes/sensores com certificação SR (ver também: <http://www.lighting.philips.co.uk/oem-emea/products/driving-connected-lighting>). A compatibilidade funcional de 2 componentes/sensores (com certificação SR) a serem utilizados em conjunto, bem como a possibilidade de sobreposição de qualquer função LineSwitch utilizada numa luminária baseada em SR deverão ser disponibilizadas pelo fornecedor do componente/sensor principal. É necessário proceder a uma verificação integral do sistema para utilizar uma tomada NEMA de 7 pinos com uma luminária baseada em SR. O incumprimento destas recomendações poderá/irá originar o risco de danos e inconformidades relativamente aos quais a Signify não poderá assumir qualquer responsabilidade.
- DE System Ready kompatibel** - Für SR-basierte Leuchten dürfen nur SR-zertifizierte Komponenten/Sensoren verwendet werden (siehe auch: <http://www.lighting.philips.co.uk/oem-emea/products/driving-connected-lighting>). Funktionale Kompatibilität von 2 (SR-zertifizierten) Komponenten/Sensoren zur Verwendung in Kombination oder als Umgehungsmöglichkeit für Leitungsschaltungsfunktionen in einer SR-basierten Leuchte, freizugeben vom Lieferanten der Master-Komponente (Sensor). Zur Verwendung des NEMA 7 Pin-Socket an einer SR-basierten Leuchte ist eine vollständige Systemverifizierung erforderlich. Die Nichteinhaltung dieser Vorgaben kann zu Beschädigungen oder der Nichteinhaltung von Bestimmungen führen, für die Signify keinerlei Verantwortung übernehmen kann.
- FR Compatibilité SR** - Pour les luminaires qui reposent sur la technologie SR, seuls les composants/capteurs certifiés SR peuvent être utilisés (voir aussi : <http://www.lighting.philips.co.uk/oem-emea/products/driving-connected-lighting>). La compatibilité fonctionnelle de 2 composants/capteurs (certifiés SR) à utiliser ensemble ainsi que la possibilité de forçage de toute fonction d'interrupteur de ligne utilisée dans un luminaire reposant sur la technologie SR doivent être rendues possibles par le fournisseur original de composants/capteurs. Pour l'utilisation de la prise NEMA 7 broches sur un luminaire reposant sur la technologie SR, une vérification complète du système est requise. Ne pas suivre ces conseils peut/entraîner des risques de dommages et de non-conformité pour lesquels Signify ne peut être tenue pour responsable.
- IT Compatibilità SR** - Negli apparecchi in versione SR devono essere utilizzati solo componenti/sensori certificati SR (consulta anche: <http://www.lighting.philips.co.uk/oem-emea/products/driving-connected-lighting>). La compatibilità funzionale di 2 componenti/sensori (certificati SR) da utilizzare in combinazione e la possibilità di comandare la funzione lineswitch di un apparecchio di illuminazione SR, deve essere rilasciata dal fornitore del componente principale/sensore. Per utilizzare l'attacco NEMA 7pin su un apparecchio d'illuminazione SR sono necessarie delle verifiche. La mancata verifica può causare danni per non conformità per i quali Signify non si assume alcuna responsabilità.
- NL SR-compatibiliteit** - Voor SR-geschikte armaturen dienen alleen SR-gecertificeerde componenten en/of sensoren te worden gebruikt (zie ook: <http://www.lighting.philips.co.uk/oem-emea/products/driving-connected-lighting>). Functionele compatibiliteit van twee SR-gecertificeerde componenten en/of sensoren die in combinatie worden gebruikt, evenals overbruggingsmogelijkheid van een eventuele LineSwitch-functie die wordt gebruikt in een SR-geschikte armatuur, dient te worden vrijgegeven door de leverancier van de hoofdcomponent/sensor. Bij gebruik van de NEMA 7 pins aansluitbus op een SR-geschikte armatuur is een volledige systeemverificatie vereist. Het niet opvolgen van deze adviezen of het niet voldoen aan de systeemvereisten geeft risico op schade waarvoor Signify geen enkele verantwoordelijkheid kan nemen.
- DK SR-kompatibilitet** - Til SR-baserede lysarmaturer må der kun anvendes SR-certificerede komponenter/sensorer (se også: <http://www.lighting.philips.co.uk/oem-emea/products/driving-connected-lighting>). Den funktionelle kompatibilitet af 2 (SR-certificerede) komponenter/sensorer, der skal bruges i kombination med hinanden samt muligheden for tilsidesættelse af enhver LineSwitch-funktion, der bruges i et SR-baseret armatur, skal frigives af leverandøren af masterkomponent/sensor. Til brug af en 7-benet NEMA-fatning på et SR-baseret armatur kræves der en fuld systemverificering. Hvis disse råd ikke følges, kan/vil det medføre en risiko for beskadigelse og manglende overholdelse, hvilket Signify ikke kan påtage sig ansvaret for.
- SE SR-kompatibilitet** - Enbart SR-certificerade komponenter och sensorer ska användas i SR-baserade armaturer (se även: <http://www.lighting.philips.co.uk/oem-emea/products/driving-connected-lighting>). Kompatibilitet mellan två (SR-certificerade) komponenter/sensorer som ska användas tillsammans och möjlighet att åsidosätta alla LineSwitch-funktioner som används i en SR-baserad armatur kommer att släppas på marknaden av masterkomponentens/sensorns leverantör. För användning av NEMA 7-stiftsuttag på en SR-baserad armatur krävs en fullständig systemverifiering. Att inte följa dessa anvisningar medför risk för skada och innebär bristande efterlevnad som Signify inte tar något ansvar för.
- NO SR-kompatibilitet** - For SR-baserte armaturer skal bare SR-sertifiserte komponenter/sensorer brukes (se også: <http://www.lighting.philips.co.uk/oem-emea/products/driving-connected-lighting>). Funksjonell kompatibilitet av 2 (SR-sertifiserte) komponenter/sensorer som kan brukes i kombinasjon, samt overstyringsmulighet for en hvilken som helst linjeskiftfunksjon som brukes i en SR-basert lysarmatur, skal frigjøres av hovedkomponent/sensorleverandør. For bruk av NEMA 7-pinner kontakt på en SR-basert lysarmatur er det nødvendig med en fullstendig systemverifisering. Det å ikke følge disse anbefalingene kan/vil medføre risiko for skade og manglende overholdelse som Signify ikke kan ta ansvar for.
- FI SR-yhteensopivuus** - SR-valaisimissa tulee käyttää vain SR-sertifioituja komponentteja ja tunnistimia (saat lisätietoja osoitteesta <http://www.lighting.philips.co.uk/oem-emea/products/driving-connected-lighting>). Kahden käytettävän (SR-sertifioidun) komponentin/tunnistimen toimintojen yhteensopivuuden sekä SR-valaisimen kanssa käytettävän minkä tahansa linjakytintoiminnon ohitusmahdollisuuden vapauttaa komponenttien/tunnistimien päätoimittaja. Jos haluat käyttää seitsemäpikkistä NEMA-liitäntää SR-valaisimessa, järjestelmä on tarkistettava ja vahvistettava täysin. Jos et noudata tätä ohjetta, valaisin saattaa vaurioitua ja sen vaatimustenmukaisuus saattaa joutua kyseenalaiseksi. Signify ei ole tästä millään tavalla vastuussa.
- HU SR-kompatibilitás** - Az SR-alapú világítótestekkel csak SR-tanúsítású alkatrészek és érzékelők használhatók (lásd még: <http://www.lighting.philips.co.uk/oem-emea/products/driving-connected-lighting>). Két funkcionális kompatibilis (SR-tanúsítású) alkatrész, érzékelő illetve SR-alapú világítótestbe beszerelt vezérelhető hálózatoldali leválasztó kapcsoló csak akkor használható együtt, ha azok közös használatát a fő vezérlőelem (szenzor) gyártója jóváhagyta. 7-pólusú NEMA csatlakozójelzőt tartalmazó SR-alapú világítótést használata esetén a rendszer teljes működését ellenőrizni kell. Ezen tanácsok be nem tartása árokat és nem megfelelőséget okozhat, amiért a Signify nem vállal felelősséget.
- PL Zgodność z SR** - W przypadku oprav osvětleniových opartých na SR možna stosovať výlučne części/czujniki z certyfikatem SR (patrz również: <http://www.lighting.philips.co.uk/oem-emea/products/driving-connected-lighting>). Zgodność funkcjonalna dwóch części/czujników (z certyfikatem SR) stosowanych w połączeniu lub w zastępstwie dowolnej funkcji wyłącznika w oprawach opartych na SR musi być zapewniona przez dostawcę elementu nadrzędnego. Przed zastosowaniem 7-stykowego gniazda NEMA w oprawie osvětleniowej opartej na SR wymagana jest pełna weryfikacja systemu. Nieprzestrzeganie tych zaleceń jest równoznaczne z ryzykiem uszkodzenia i naruszeniem zasad użytkowania, za które firma Signify nie ponosi odpowiedzialności.



- RO **Compatibilitate SR** - Pentru corpurile de iluminat bazate pe SR, trebuie să se utilizeze numai componentele/senzorii cu certificare SR (consultați, de asemenea: <http://www.lighting.philips.co.uk/oem-emea/products/driving-connected-lighting>). Compatibilitate funcțională a 2 componente/senzori (cu certificare SR) care trebuie să fie utilizați în asociere, precum și posibilitate de a anula orice funcție lineswitch utilizată într-un corp de iluminat bazat pe SR, lucru care trebuie autorizat de furnizorul componente/senzorului principal. Pentru utilizarea soclului cu 7 pini NEMA la un corp de iluminat bazat pe SR, este necesară o verificare completă a sistemului. Nerespectarea acestor recomandări poate duce la/va cauza risc de avarie și neconformitate, pentru care Signify nu își poate asuma nicio responsabilitate.
- CZ **Kompatibilita s SR** - U svítidel SR se používají pouze SR certifikované součásti/snímače (viz též <http://www.lighting.philips.co.uk/oem-emea/products/driving-connected-lighting>). Funkční kompatibilitu dvou součástí nebo snímačů (s certifikací SR) při použití v kombinaci a možnost potlačení funkce LineSwitch, používaných u svítidel SR, musí posoudit dodavatel hlavní součásti nebo snímače. Pro použití 7kolíkové zásuvky NEMA na svítidle s certifikací SR je vyžadováno úplné ověření systému. Nedodržení těchto doporučení může způsobit poškození a nesoulad, za něž Signify nenese žádnou odpovědnost.
- TR **SR uyumluluğu** - SR tabanlı aydınlatma armatürleri için yalnızca SR Sertifikalı bileşenler/sensörler kullanılmalıdır (ayrıca bkz. <http://www.lighting.philips.co.uk/oem-emea/products/driving-connected-lighting>). Birlikte kullanılacak 2 (SR sertifikalı) bileşen/sensörün işlevsel uyumluluğu ve SR tabanlı aydınlatma armatüründe kullanılan herhangi bir lineswitch işlevinin geçersiz kılınma olasılığı, ana bileşen/sensör tedarikçisi tarafından sağlanacaktır. SR tabanlı aydınlatma armatüründe NEMA 7 pimli soketin kullanılması için tam sistem doğrulaması gereklidir. Bu tavsiyelere uymamak, Signify'in sorumlu tutulamayacağı hasar riskine ve uyumsuzluğa neden olabilir.
- SK **Kompatibilita SR** - Pri svietidlách založených na SR sa smú používať len SR certifikované komponenty/snímače (pozri tiež: <http://www.lighting.philips.co.uk/oem-emea/products/driving-connected-lighting>). Funkčnú kompatibilitu 2 (SR certifikovaných) komponentov/snímačov na použitie v kombinácii, ako aj možnosť zrušenia funkcie spínača použitej v svietidle založenom na SR, má zabezpečiť dodávateľ hlavného komponentu/snímača. Pri použití 7-kolíkovkej objímky NEMA v svietidle založenom na SR sa vyžaduje overenie celého systému. Nedodržanie týchto pokynov môže spôsobiť/spôsobí poškodenie a nesúlad, za ktoré spoločnosť Signify nemôže niesť zodpovednosť.
- GR **Συμβατότητα SR** - Για τα φωτιστικά που βασίζονται στο SR, πρέπει να χρησιμοποιούνται μόνο εξαρτήματα/αισθητήρες με πιστοποίηση SR (δείτε επίσης: <http://www.lighting.philips.co.uk/oem-emea/products/driving-connected-lighting>). Η λειτουργική συμβατότητα 2 εξαρτημάτων/αισθητήρων (με πιστοποίηση SR) που θα χρησιμοποιηθούν σε συνδυασμό, καθώς και η δυνατότητα παράκαμψης οποιασδήποτε λειτουργίας lineswitch που χρησιμοποιείται σε ένα φωτιστικό που βασίζεται στο SR, θα πρέπει να κοινοποιηθεί από τον προμηθευτή του κύριου εξαρτήματος/αισθητήρα. Για τη χρήση υποδοχής NEMA 7 ακίδων σε φωτιστικό που βασίζεται στο SR, απαιτείται πλήρης επαλήθευση συστήματος. Αν δεν ληφθούν υπόψη αυτές οι συμβουλές, μπορεί να/θα προκληθεί κίνδυνος ζημιάς και μη συμμόρφωσης, για τα οποία η Signify δεν μπορεί να αναλάβει καμία ευθύνη.
- RS **Совместимость с устройствами SR** - Светильники на основе технологий SR совместимы только с компонентами/датчиками, сертифицированными для использования с технологией SR (см. также: <http://www.lighting.philips.co.uk/oem-emea/products/driving-connected-lighting>). Функциональная совместимость используемых в сочетании 2 компонентов/датчиков (сертифицированных для использования с технологией SR), а также возможность переопределяющего управления любой функцией уменьшения яркости LineSwitch при использовании светильника на основе технологии SR определяется поставщиком основного компонента/датчика. Для использования 7-контактного гнезда NEMA на светильнике на основе технологии SR требуется полная проверка системы. Несоблюдение этих рекомендаций с высокой вероятностью может привести к возможным повреждениям и несоответствию системы спецификациям, за которые компания Signify не несет какой-либо ответственности.
- BG **Съвместимост и функционална готовност за свързване към система за управление /SR compatibility/-** За осветителните тела с вградена функционална готовност за свързване към система за управление трябва да се използват само компоненти сертифицирани за тази цел (моля вижте следния линк : <http://www.lighting.philips.co.uk/oem-emea/products/driving-connected-lighting>). Функционалната съвместимост на два сертифицирани за използване в осветителните тела с вградена готовност за свързване към система за управление, (SR certified) компонента/сензора, които се използват в комбинация, както и възможността за използване на пълната функционалност на предварително готови за свързване към система за управление /SR based/ осветителни тела трябва да бъде осигурена от доставчика на съответния компонент/сензор. Ако се използва конектор NEMA със 7 щифта на осветителните тела с предварителна функционална готовност за свързване към система за управление /SR based/ трябва да се направи проверка на съвместимостта на цялата система и нейните съставни компоненти. Неспазването на този съвет може/ще доведе до риск от повреда и несъответствие, за което Сигнифай Интернешънъл не носи отговорност.
- HR **SR kompatibilnost** – Za SR pripremljene svjetiljke, samo SR certificirane komponente/senzori smiju biti korišteni (detaljno dostupno na: <http://www.lighting.philips.co.uk/oem-emea/products/driving-connected-lighting>). Funkcionalna kompatibilnost dvaju (SR certificiranih) komponenti/senzora za korištenje u kombinaciji, kao i mogućnosti prisilnog preklopa funkcija preklapanja mreže korištenog u SR pripremljenim svjetiljkama treba biti potvrđena od strane dobavljača master odnosno senzor SR komponenti. U slučaju korištenja NEMA 7-pin konektora na SR pripremljenim svjetiljkama, potrebna je cjelovita systemska verifikacija te kombinacije prije korištenja. Nepoštivanje ovog savjeta će stvarno ili potencijalno uzrokovati rizik kvara ili nepravilnog funkcioniranja sistema za koje Signify ne može preuzeti odgovornost.
- LT **SR (system ready) suderinamumas** – Šviestuvuose su SR galima naudoti tik SR sertifikuotus komponentus / jutiklius (taip pat žiūrėkite: <http://www.lighting.philips.co.uk/oem-emea/products/driving-connected-lighting>). Komponentų / jutiklių tiekėjas turi užtikrinti tinkamą dviejų (SR sertifikuotų) komponentų / jutiklių, kurie bus naudojami kartu, funkcinį suderinamumą, taip pat galimybę panaikinti bet kurią linijinio perjungimo funkciją, naudojamą šviestuve su SR. Jei SR šviestuve naudojamas NEMA 7 kontaktų lizdas, būtina papildomai atlikti visos sistemos patikrą. Šių nurodymų nesilaikymas gali įtakoti sugadinimą ir nesuderinamumą/neveikimą, už kuriuos „Signify“ nepriima jokios atsakomybės.
- LV **SR saderība** – Gaismekļiem uz SR bāzes ir izmantojami tikai SR sertificēti komponenti/sensori (skatīt arī: <http://www.lighting.philips.co.uk/oem-emea/products/driving-connected-lighting>). Funkcionāla saderība starp diviem (SR sertificētiem) komponentiem/sensoriem, kurus izmantos kopā, kā arī, ignorēšanas iespējas jebkuras līnijas pārslēgšanas funkcijas, kas tiks izmantotas SR bāzes gaismekļos, ir jāsniedz galvenā komponenta / sensora piegādātājam. Ja izmanto NEMA 7 – pin ligzdu kopā ar SR bazēto gaismekli, verifikācija ir obligāta visai sistēmai. Šī ieteikuma neievērošana var radīt / radīs kaitējuma un neatbilstības risku, par kuru Signify nevar uzņemties nekādu atbildību.
- EE **SR ühilduvus** – SR-põhiste valgustite puhul tuleb kasutada ainult SR-sertifikaadiga komponente/andureid (vt ka: <http://www.lighting.philips.co.uk/oem-emea/products/driving-connected-lighting>). SR-sertifitseeritud seadme/anduri tarnija peab lubama ja vastutama kahe kombineeritud SR seadme/anduri funktsionaalse ühilduvuse ja juhtsoone (Lineswitch) funktsiooni kasutamisel seadete alistamise SR valmidusega valgustis. Kui kasutate SR-põhisel valgustil NEMA 7-pin pistikut, on vajalik süsteemi vastavuse täielik kontroll. Selle nõude mittejärgimine võib põhjustada kahju tekkimist ja mittevastavust, mille eest Signify ei vastuta.
- SI **Združljivost s SR** – Za svetilke, ki temeljijo na SR, se smejo uporabiti samo certificirane SR komponente / senzori, (glejte tudi: <http://www.lighting.philips.co.uk/oem-emea/products/driving-connected-lighting>). Funkcionalno združljivost komponent / senzorjev, ki jih je treba uporabiti v kombinaciji, kot tudi možnost preglasovanja katere koli funkcije linijskega stikala, mora sprostiti glavni dobavitelj komponent / senzorjev. Če uporabljate 7-pin vtičnico NEMA v svetilki, ki temelji na SR, je potrebna celovita verifikacija sistema. Neupoštevanje teh navodil lahko povzroči škodo in neskladnosti, za kar podjetje Signify ne prevzema nobene odgovornosti.



GB - Disconnect before servicing

FR - Mettre hors tension avant intervention

DE - Öffnen nur spannungsfrei

NL - Stroom afsluiten voor onderhoud

LT - Pirms apkopes atvienojiet no elektrības

EE - Katkesta elektritoide enne valgusti hooldust/remonti

PT - Desconecte antes de fazer a manutenção

DK - Frakobl, før service

NO - Koble fra før service

FI - Irrota pistoke ennen huolto

CZ - Před servisem se odpojte

TR - Servis yapmadan önce bağılantıyı kesin

HR - Prije servisiranja isključite

GR - Αποσυνδέστε πριν από τη συντήρηση

BG - Изключете преди сервис

RU - Отключите перед обслуживанием

LV - Pirms apkopes atvienojiet to

IT - Togliere tensione prima di fare manutenzione

ES - Desconectar antes de manipular

SE - Bryt strömmen före lampbyte

SK - Odpojit pred údržbou

SI - Pred servisiranjem izključite svetilko

HU - Karbantartás előtt húzza ki a csatlakozót

PL - Odłącz przed serwisowaniem

RO - Deconectați-vă înainte de întreținere

GB	Luminaire has basic insulation between Low Voltage supply and control conductors.	SE	Armaturen har enkelisolering mellan lågvoltförsörjningen och styrledningarna.	GR	Το φωτιστικό διαθέτει βασική μόνωση μεταξύ της χαμηλής τάσης τροφοδοσίας και των αγώγων ελέγχου.
ES	La luminaria tiene un aislamiento básico entre la alimentación de baja tensión y los cables de la señal de control.	NO	Armaturet har enkelisolering mellom lavvoltforsyningen og styreledningene.	CZ	Ve svítidle je mezi vodiči napájení a řízení základní izolace.
PT	A luminária tem um isolamento básico entre a alimentação de baixa tensão e os cabos de sinal de controlo.	FI	Valaisimessa on peruseristys syöttöjännitteen ja ohjausohjotmien välillä.	TR	Armatur, Alçak Gerilim beslemesi ile kontrol iletkenleri arasında temel izolasyona sahiptir
DE	Die Leuchte verfügt über eine einfachen Isolation zwischen der Niederspannungsversorgung und den Steuerleitungen.	HU	A lámpatest kifeszűltségű és szabályozó bemenetei galvanikusan el vannak választva.	SK	Svietidlo má základnú izoláciu medzi vodičmi zdroja nízkeho napätia a ríadiacimi vodičmi.
FR	Le luminaire comporte une isolation de base entre l'alimentation basse tension et les câbles de contrôle.	RO	Corpul de iluminat dispune de izolație de bază între sistemul de alimentare de joasă și conductorii de control.	LT	Šviestuvus turi elementarią izoliaciją tarp žemos įtampos maitinimo ir valdymo laidų.
IT	Il grado di isolamento tra il conduttore di alimentazione ed il conduttore di segnale è básico.	BG	Осветителното тяло има основна изолация между захранването ниско напрежение и контролните проводници.	LV	Gaismeklim ir pamata izolācija starp zemsprieguma barošanas un vadības aprīkojuma.
NL	Armatuur heeft een basisisolatie tussen laagspannings-voeding en controle bedrading.	RU	Светильник обладает базовой электроизоляцией между низковольтным блоком питания и управляющими проводниками.	EE	Valgustil on põhiisolatsioon madalpinge toite ja juhtimiseadmete vahel.
DK	Armaturet har enkelisolering mellem lavvoltforsyningen og styreledningerne.	PL	Oprawa posiada podstawową izolację pomiędzy modulem zasilania niskonapięciowego i przewodami sterującymi.	SI	Svetilka ima osnovno izolacijo med nizkonapetostnimi napajalnimi in regulacijskimi vodniki.
GR	The light source and/or control gear and/or the external flexible cable contained in this luminaire shall only be replaced by the manufacturer or his service agent or a similar qualified person.	RO	Sursa de lumină și / sau aparatura și / sau cablul flexibil extern conținut în acest aparat de iluminat trebuie înlocuite numai de producător sau de agentul său de service sau de o persoană calificată similară.	HR	Svjetiljka ima osnovnu izolaciju između napajanja i upravljačkih konektora.
ES	La fuente de luz/o el driver / o el cable flexible contenido en la luminaria solo podrá ser sustituido por el fabricante o su agente de servicio o por una persona cualificada.	FI	Tässä valaisimessa oleva valonlähde ja/tai muut komponentit, kuten liitäntälaitte ja/tai ulkoiset kaapelit saadaan vaihtaa vain valmistajan tai tämän valtuuttaman huoltoedustajan tai vastaavan pätevän henkilön toimesta.	TR	Bu armatürde bulunan ışık kaynağı ve / veya kontrol tertibatı ve / veya harici esnek kablo, yalnızca imalatçı veya onun servis temsilcisi veya benzer bir kalifiye kişi tarafından değiştirilmelidir.
PT	A fonte de luz e/ou o equipamento de controlo e/ou o cabo externo flexível nesta luminária só devem ser substituídos pelo fabricante ou pelo seu agente de serviço ou por pessoa qualificada para tal.	HR	Izvor svjetlosti i / ili predspojna naprava i / ili vanjski fleksibilni napojni kabel sadržan u ovoj svjetiljci smije zamijeniti samo proizvođač, ovlaštenu osobu ili adekvatna stručno osposobljena i ovlaštena osoba.	GR	Η φωτεινή πηγή ή/και το όργανο έναυσης/ελέγχου ή/και το εξωτερικό εύκαμπτο καλώδιο που περιέχεται στο εν λόγω φωτιστικό πρέπει να αντικαθίστανται μόνο από τον κατασκευαστή ή τον αντιπρόσωπο σέρβις ή παρόμοιο ειδικευμένο πρόσωπο.
DE	Die in dieser Leuchte enthaltene Lichtquelle und/oder das Betriebsgerät und/oder das externe flexible Anschlusskable darf nur vom Hersteller oder seinem Kundendienst oder einer ähnlich qualifizierten Person ausgetauscht werden.	BG	Източникът на светлина и / или пусково-регулируща апаратура и / или външният гъвкав кабел, съдържащ се в това осветително тяло, трябва да бъдат заменени само от производителя или неговия оторизиран сервиз или подобно квалифицирано лице.	LV	Gaismas avotu un / vai vadības ierīci un / vai ārējo elastīgo kabeli, kas atrodas šajā gaismeklī, drīkst nomainīt tikai ražotājs vai viņa servisa pārstāvis vai līdzīga kvalificēta persona.
FR	La source lumineuse et/ou le contrôleur de courant et/ou le câble souple d'alimentation contenus dans ce luminaire ne doivent être remplacés que par le fabricant, un de ses agents ou une personne qualifiée.	RU	Источник света и / или ПРА и / или внешний гибкий кабель, содержащиеся в этом светильнике, могут быть заменены только производителем, его агентом по обслуживанию или аналогичным квалифицированным лицом.	EE	Selles valgustis sisalduva valgusalikika ja/või juhtimiseadme ja/või välise painduva kaabli võib välja vahetada ainult tootja, vastav hoolduspetsialist või muu sarnane kvalifitseeritud isik.
IT	La sorgente luminosa e/o il dispositivo di controllo e/o il cavo flessibile esterno contenuti in questo apparecchio di illuminazione sono sostituiti solo dal costruttore o dal suo agente di servizio o da una persona qualificata analoga.	SK	Svetelný zdroj a/alebo predradník a/alebo externý flexibilný kábel obsiahnutý v tomto svietidle môže byť vymenený len výrobcom alebo servisným partnerom alebo inou podobne kvalifikovanou osobou.	SI	Vir svetlobe in / ali napajalnik in / ali zunanji prilagodljivi kabel, ki ga vsebuje ta svetilka, lahko zamenja le proizvajalec ali njegov servis ali podobna usposobljena oseba.
NL	De lichtbron en/of voorschakelapparatuur en/of de flexibele voedingskabel van dit armatuur mag alleen vervangen worden door de fabrikant of haar service dealer of een vergelijkbaar gekwalificeerd persoon.	LT	Šviesos šaltinis ir/arba valdymo įrenginys ir/arba išorinis lankstus kabelis esantis šiame šviestuve gali būti pakeistas tik gamintojo arba jo aptarnavimo agento ar tai atitinkancio kvalifikuoto asmens.		
DK	Lyskilden og/eller driver og/eller eksterne kabler indeholdt i dette armatur må kun udskiftes af producenten eller godkendt service partner eller lignende kvalificeret person.	LV	Gaismas avotu un / vai vadības ierīci un / vai ārējo elastīgo kabeli, kas atrodas šajā gaismeklī, drīkst nomainīt tikai ražotājs vai viņa servisa pārstāvis vai līdzīga kvalificēta persona.		
SE	Ljuskällan och/eller styrsystemet och/eller den externa kabeln i denna armatur får endast bytas ut av tillverkaren eller en kvalificerad person.	EE	Selles valgustis sisalduva valgusalikika ja/või juhtimiseadme ja/või välise painduva kaabli võib välja vahetada ainult tootja, vastav hoolduspetsialist või muu sarnane kvalifitseeritud isik.		
NO	Lyskilden og/eller driveren og/eller den eksterne kabelen i dette armaturet skal bare erstattes av produsenten eller dens service agent eller tilsvarende kvalifisert person.	SI	Vir svetlobe in / ali napajalnik in / ali zunanji prilagodljivi kabel, ki ga vsebuje ta svetilka, lahko zamenja le proizvajalec ali njegov servis ali podobna usposobljena oseba.		
CZ	Světelný zdroj a/nebo napájecí zdroj (předradník) a/nebo flexibilní napájecí kabel v tomto svítidle smí vyměňovat pouze výrobce nebo jeho servisní technik nebo obdobně kvalifikovaná osoba.				
HU	A lámpatestben található fényforrást és/vagy működtető szerelvényt és/vagy a külső rugalmas kábel csak a gyártó, a gyártóval szerződött cég vagy megfelelő képzéssel rendelkező szakember cserélheti ki.				
PL	Źródło światła i/lub zasilacz i/lub zewnętrzny przewód zasilający, który jest w oparciu powinien być wymieniony przez producenta lub jego serwisanta lub kwalifikowany personel.				



© 2021 Signify Holding.

All rights reserved. This document contains information relating to the product portfolio of Signify which information may be subject to change. No representation or warranty as to the accuracy or completeness of the information included herein is given and any liability for any action in reliance thereon is disclaimed. The information presented in this document is not intended as any commercial offer and does not form part of any quotation or contract. Philips and the Philips Shield Emblem are registered trademarks of Koninklijke Philips N.V.. All other trademarks are owned by Signify Holding or their respective owners.

Signify Holding.