

# DynaFlood LED Mono

## Installation Instructions

Instructions de montage  
Montageanleitung  
Montage Instruktie  
Istruzioni di montaggio

Instrucciones de montaje  
Instruções de montagem  
Monteringsinstruktioner  
Monteringsvejledning

Kokoonpano- ja kiinnitysohjeet  
Montaj yönergesi  
Οδηγίες συναρμολόγησης  
Instrukcja montażu

Szerelési utasítások  
Návod k montáži  
ИНСТРУКЦИЯ ПО МОНТАЖУ  
Návod k montáži

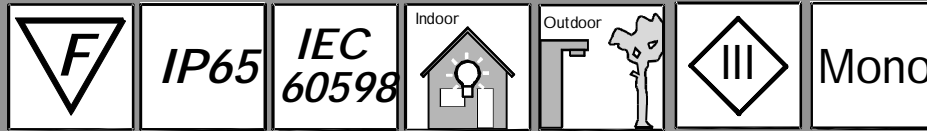

|                               | LEDs | Voltage | Class | Pmax (W) | L (mm) | kg  |
|-------------------------------|------|---------|-------|----------|--------|-----|
| BCS 435-36xLED/<br>LXN XX 24V | 36   | 24V DC  | III   | 42       | 350    | 3.7 |
| BCS 445-48xLED/<br>LXN XX 24V | 48   | 24V DC  | III   | 56       | 450    | 4.1 |
| BCS 455-60xLED/<br>LXN XX 24V | 60   | 24V DC  | III   | 70       | 550    | 4.6 |

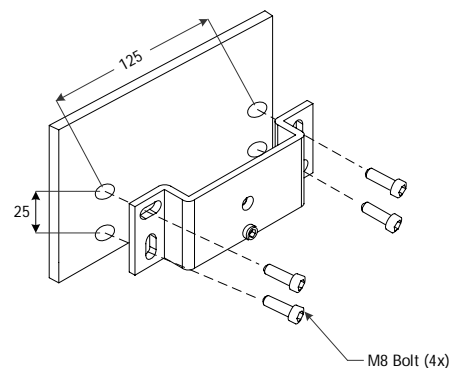
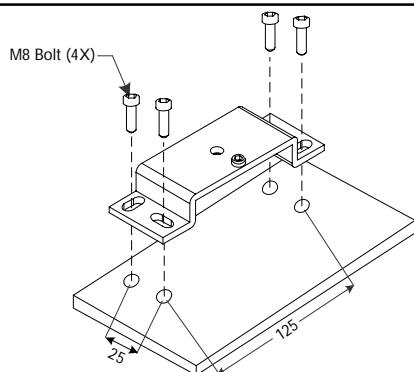
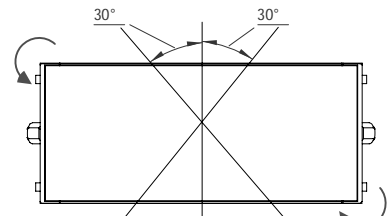
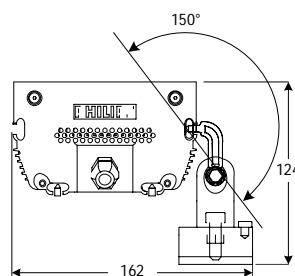
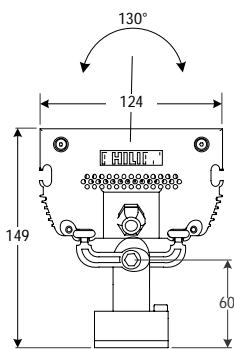
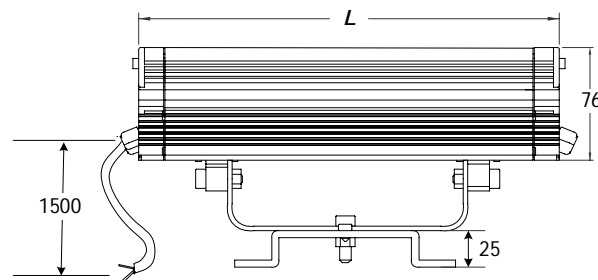

# PHILIPS

1a

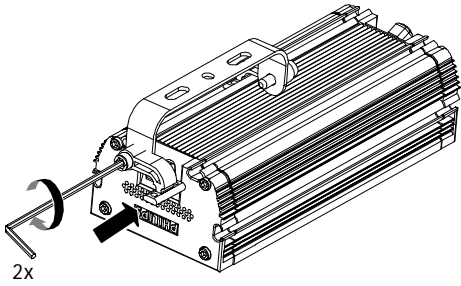

1b

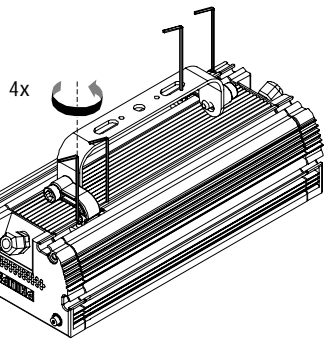

1c

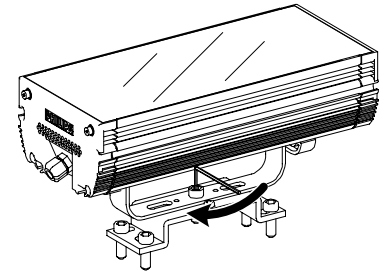

1d

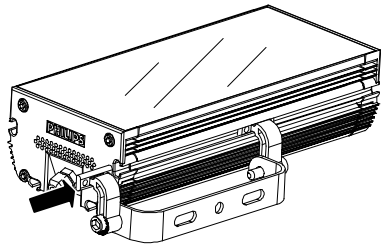

1e

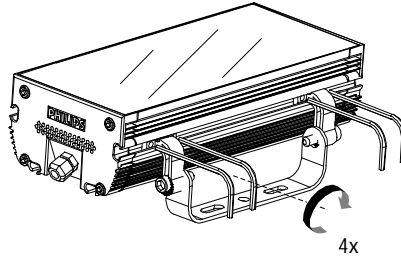

1f

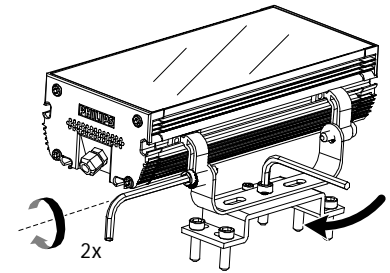

2

*PS150/100/050 power supply unit to be ordered separately*

**Maximum luminaire loading quantity**

| Luminaire  | PS150 |
|------------|-------|
| BCS 435-36 | 3 pcs |
| BCS 445-48 | 2 pcs |
| BCS 455-60 | 1 pcs |

