

Batten LED

Version date 04/06
www.lighting.philips.com

Installation instructions

Instructions de montage
Montageanleitung
Montage instructie
Istruzioni di montaggio

Instrucciones de montaje
Instruções de montagem
Monteringsinstruktioner
Monteringsvejledning

Kokoonpano- ja kiinnitysohjeet
Montaj yönergeleri
Οδηγίες συναρμολόγησης
Instrukcja montażu

Szerelési utasítások
Návod k montáži
ИНСТРУКЦИЯ ПО МОНТАЖУ
Návod k montáži

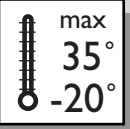
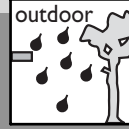
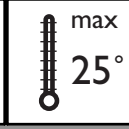

.....LEDs	V	Pmax (W)	L(mm)	kg
BCS603-24	24V DC	2	300	1.0
BCS606-48		4	595	1.2
BCS609-72		6	890	1.5
BCS612-96		8	1185	2.0

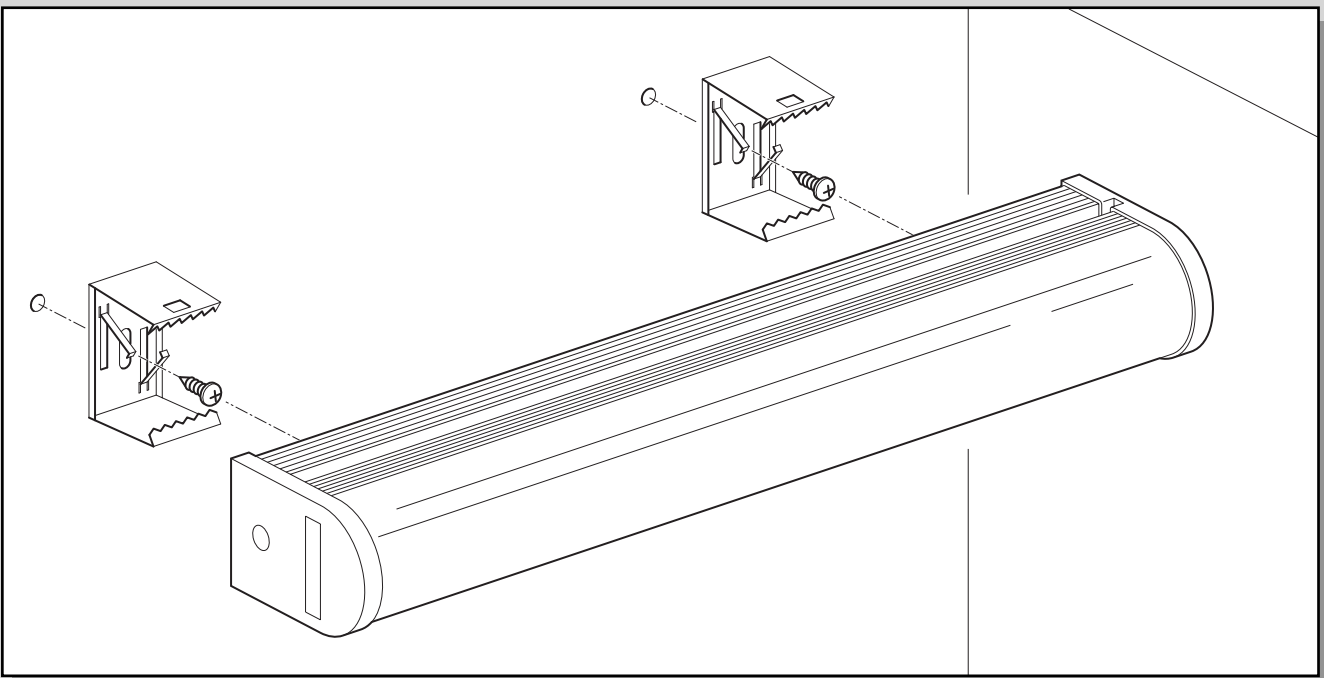
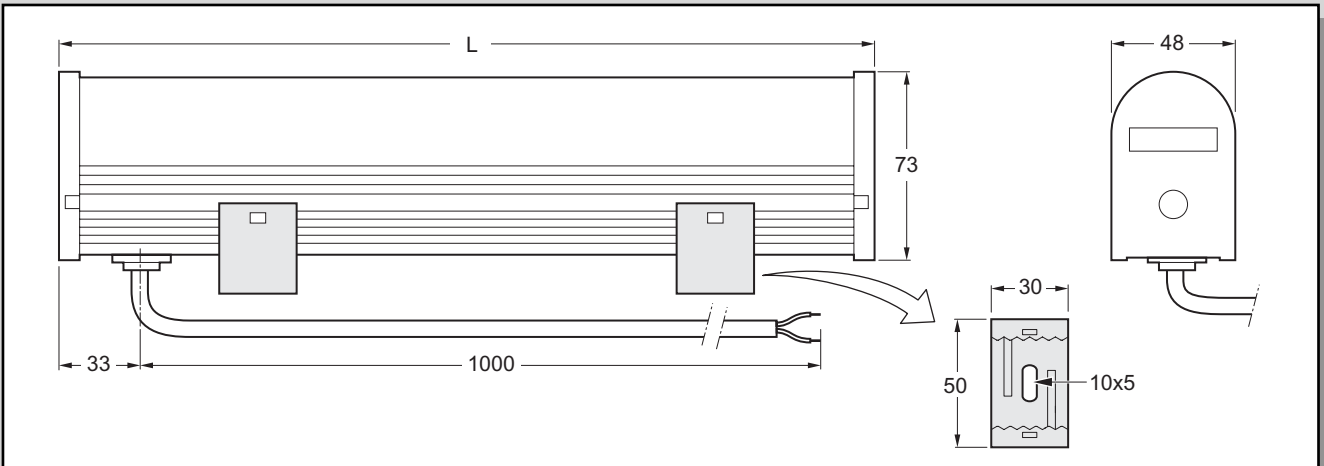

PHILIPS

Power unit to be ordered separately.

PS050	50W	9105 028 52818
PS100	100W	9105 029 52818
PS150	150W	9105 030 52818

Maximum luminaire loading quantity.

Luminaire	PS150 (N)	PS100 (N)	PS050 (N)
BCS603-24	53	35	18
BCS606-48	27	18	9
BCS609-72	19	12	6
BCS612-96	14	9	5

