

H.I.D. lamps

Blended light (self-ballasted) ML (-R)



ML



MLR

These lamps consist of a gas-filled ovoid glass bulb internally coated with a phosphor. They contain a quartz high-pressure mercury-discharge tube connected in series with a tungsten filament which acts both as an incandescent light source and as a current-limiting device. They offer a combination of high luminous flux and good colour rendering. MLR lamps include an internal reflector.

The outer bulb is filled with a mixture of argon and a percentage of nitrogen. ML lamps emit a spectrum composed of a continuum from the incandescent source and a line spectrum from the high-pressure mercury source.

Blended light lamps cannot be dimmed.

The self-ballasting ML lamps are a direct retrofit in luminaires for incandescent lamps.

It is advisable to protect the normal glass types (100 W, 160 W and 250 W versions) against water splashes.

ML 100 W and 160 W: burning position of +/- 30 degs, base up or down.

ML 250 W and 500 W: universal burning position permissible, but vertical position +/- 45 degs. base up or down recommended, especially when undervoltage is expected.

MLR lamps: base up +/- 30 degs.

Applications

- ML: streets, squares, car parks, petrol stations, workshops, garages and shops.
- MLR: plant irradiation, workshops, small industrial units, garages, shops and petrol stations.

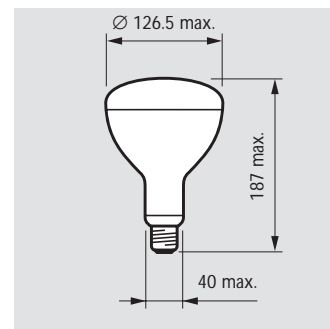
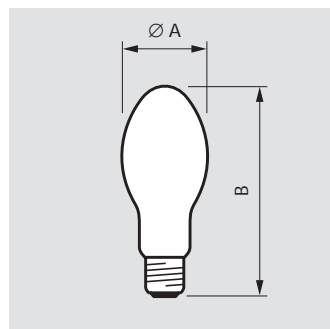
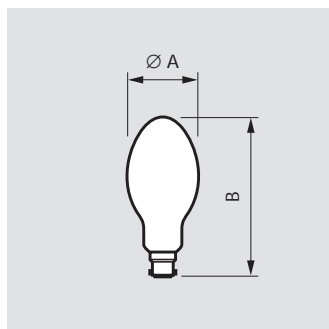
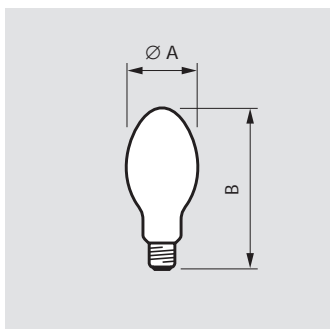

MLR 160 W E27

Dimensions in mm

Type	A	B
Cap/base E27		
ML 100W	70.0±1.0	151.0±4.0
ML 160W	75.0±1.0	168.0±5.0
ML 250W	90.0±1.0	211.0±6.0

Type	A	B
Cap/base B22d		
ML 100W	70.0±1.0	149.5±4.0
ML 160W	75.0±1.0	166.5±5.0

Type	A	B
Cap/base E40		
ML 250W	90.0±1.0	224.0±6.0
ML 500W	120.0±1.5	282.0±8.0

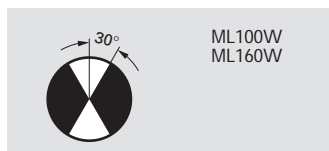

Burning positions

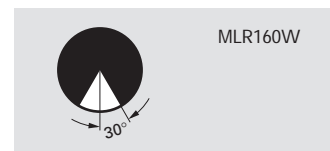
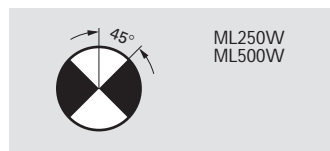

H.I.D. lamps

Blended light (self-ballasted) ML (-R)

Commercial name	Wattage		Cap/ base	Lamp wattage		Lamp current	Lumen output	Correlated colour temp.	Chrom. coord. x	Chrom. coord. y	Colour rendering index	Maximum permissible base/pinch temp. degr.C	Maximum permissible bulb temp. degr.C	Nett weight g	EOC
	W	V		W	V										
ML	100	225-235	E27	106	225	0.48	1100	3300	419	385	72	200	350	52	180483
ML	100	235-245	B22D	108	245	0.46	1100	3300	417	384	72	200	350	67	181206
ML	100	235-245	E27	108	245	0.46	1100	3300	417	384	72	200	350	52	181176
ML	160	225-235	B22D	165	225	0.76	3150	3600	399	380	61	200	350	90	181442
ML	160	225-235	E27	165	225	0.76	3150	3600	399	380	61	200	350	90	181350
ML	160	235-245	B22D	165	245	0.69	2800	3600	395	379	61	200	350	90	181503
ML	160	235-245	E27	165	245	0.69	2800	3600	395	379	61	200	350	90	181473
ML	250	225-235	E27	260	225	1.20	5500	3400	403	382	63	200	350	115	201393
ML	250	225-235	E40	260	225	1.20	5500	3400	403	382	63	200	350	145	201294
ML	250	235-245	E27	265	245	1.09	5300	3400	399	381	63	200	350	115	201416
ML	250	235-245	E40	265	245	1.09	5300	3400	399	381	63	200	350	145	201317
ML	500	225-235	E40	500	225	2.32	13000	3700	396	387	48	250	350	250	201331
ML	500	235-245	E40	500	245	2.13	13000	3700	393	386	48	250	350	250	201355
MLR															
MLR	160	225-235	E27	160	225	0.75	2800	3400	401	390	62	200	350	153	183828
MLR	160	235-245	E27	163	245	0.68	2450	3400	398	390	62	200	350	153	183859

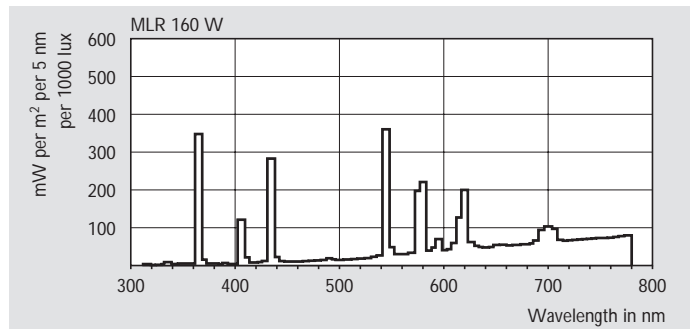
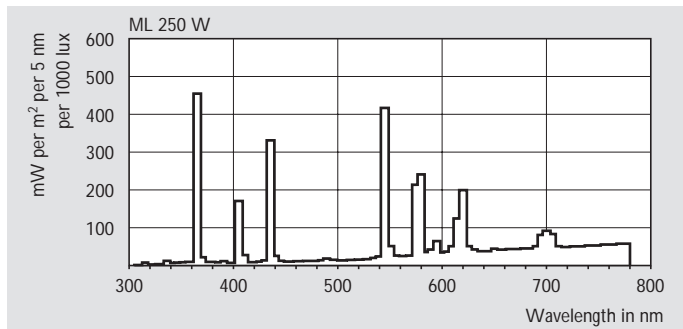

Spectral power distributions

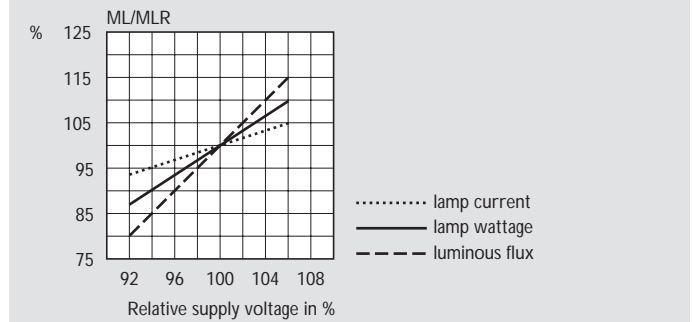
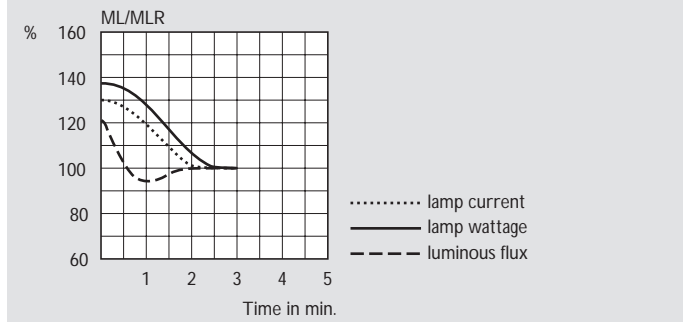

Lamp performance during run-up

Effects of mains voltage variations

