



# 1,000 shades of white light

**Philips Lexel LED DLM system** – A flexible LED lighting solution creating thousands of shades of white light and colors from a single source

**PHILIPS**  
sense and simplicity

# 1,000 shades of white light

The Philips Lexel LED DLM system is designed for general lighting applications in the professional market, enabling the creation of various atmospheres with changing tones of white light and different colors from a single light source.

The system consists of an LED module and a dedicated LED driver, with a cable (optional) designed for use in new luminaires together with a heatsink, reflector design and a user-interface.

A unique intelligent feedback system guarantees precise selection of white color temperature (CCT) from 2,700 to 6,500K, color rendering (R<sub>a</sub>) 80 or higher and color consistency between modules and over lifetime.

This future-proof system has fixed form and lumen packages and external heatsink and optics can be easily attached to the module. Dimmable and featuring instant 100% light, they run through a unique control interface that allows the same light source to be used on a DALI, DMX/RDM network. Philips Lexel LED DLM SYSTEM is a comfortable lighting solution that emits no heat or UV which also benefits retailers looking to preserve the color fastness of their products or garments.



3,175k

4,125k

5,075k

6,025k

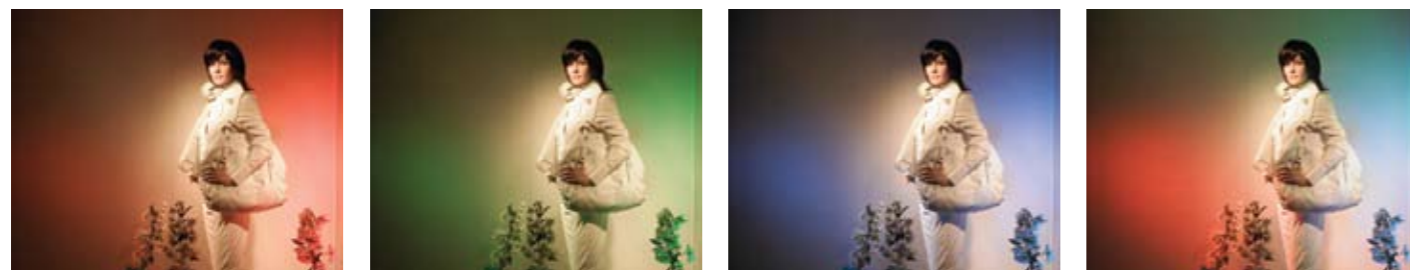
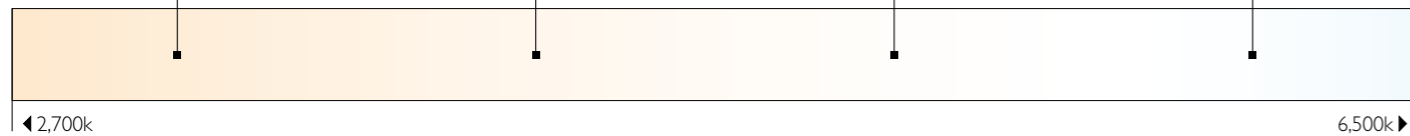

## Benefits

- Create various lighting atmospheres with a single light source
- Color quality and consistency over time and among modules
- Uniform colors even in shadows
- Enable a faster luminaire creation process
- Access to the latest LED technology without significant R&D investments
- Very high optical luminaire efficiency
- Comfortable, pleasant light without heat or UV
- Fixed form factor and lumen package
- Long lifetime of 50,000 hrs

## Applications

- Shops – Shop windows, wall-washers, leisure areas, focus islands and shop-in-shop concepts
- Offices – Presentation areas such as reception, boardrooms and restaurants
- Hospitality – Lobbies, reception areas, restaurants, bars, elevator halls
- Recreation – Museums, galleries, theaters and other places of interest

## Driver

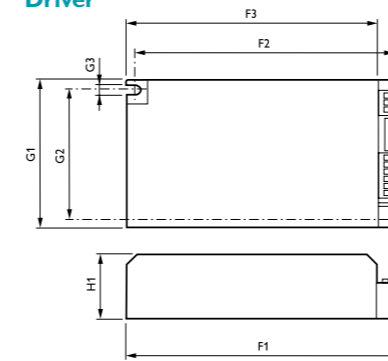

## Module

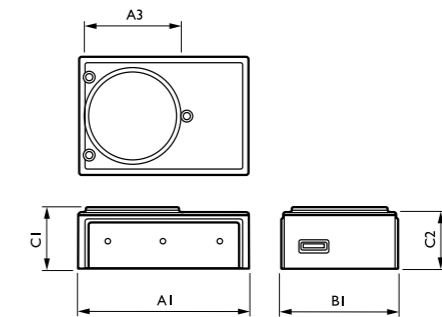

## Dimensions (typical data; ± 0.2mm)

	A1	A2	A3	B1	C1	C2	F1	F2	F3	G1	G2	G3	H1
Lexel LED DLM I 100	121.6	-	66.8	82.8	43.7	40.2	138	128.5	124.5	74	63.6	4.5	32

## Commercial Specifications Philips Lexel LED DLM I 100

Philips Lexel LED DLM system	Power (W)	Light Output (lm)	Efficacy LED module + driver (lm/W)	Comparable LED efficiency (lm/W)	Input voltage (V)	Input Frequency (Hz)	Colour Temperature (K)	Colour rendering index (R <sub>a</sub> )	RGB
Lexel LED DLM I 100 40W DALI/DMX	40	1,100	25	110	220-240	50-63	2,700 - 6,500	80	R: (X=0.610,Y=0.320) G: (X=0.250,Y=0.610) B: (X=0.200,Y=0.160)

Philips Fortimo LED DLM system	Colour consistency initial & @10K hrs. (SDCM)	Lumen maintenance @35K hrs. (%)	Control Interface	Dimming	Class	Power factor	Total harmonic distortion (%)	Tc Life LED module (°C)	Tc max LED module (°C)	Tc Life LED driver (°C)	Burning position
Lexel LED DLM I 100 40W DALI/DMX	5 / 6	70	DALI, DMX/ RDM	100-10%	I	>0.90	<20%	65	65	65	Universal

Philips Lexel LED DLM is a dynamic system therefore product specifications as power, light output and color rendering are not constant. For details please consult the Technical Application Guide for this system.

[www.philips.com/lexel](http://www.philips.com/lexel)



©2008 Koninklijke Philips Electronics N.V.

All rights reserved. Reproduction in whole or in part is prohibited without the prior written consent of the copyright owner. The information presented in this document does not form part of any quotation or contract, is believed to be accurate and reliable and may be changed without notice. No liability will be accepted by the publisher for any consequence of its use. Publication thereof does not convey nor imply any license under patent- or other industrial or intellectual property rights.

Date of release: September 2008 / UK - 3222 635 5725 I  
Printed in the Netherlands