



Great signs for great brands

Philips Affinium LED string system (low power), combines easy installation with guaranteed brand identity benefits for your customer channel letters of 0.3-2 meter high and other signage applications.

As a sign maker or reseller, you know that your job is to enhance and protect your customers' brands. They want signs that look great and keep working perfectly over long periods. The Philips Affinium LED string system is designed to guarantee this.

Philips enables you to protect your customers' brands by offering you an easy-to-install LED string system, including both LED string and driver. The system can be used in virtually every situation, thanks to its fully outdoor proof IP66 rating. Excellent light quality and uniformity are ensured by the broad viewing angle plus the flexible string wiring, which allows accurate positioning of the individual LEDs.

Big benefits for signmakers

- Easy installation
- Outdoor proof
- Excellent light and color uniformity of your signs

Easy installation

The LED strings are very flexible and can be cut at any position and attached to your backplate with a choice of mounting clips or tape. This enables fast layouts and installation, saving you time and money. The system operates at 24V making it safe to install.

Outdoor proof

Both the overall LED string system and all individual components are fully outdoor proof and have an IP66 rating, ensuring high reliability under all operating conditions. What's more, the LED string starts instantly, even at temperatures as low as -20°C. High operating temperatures are also no problem, for example in warm locations exposed to strong sunshine.

Quality and uniformity of light

To ensure a uniform light distribution in your signs, the LEDs in the string have a broad angle of light output (angle of luminous flux is 130° for the colored LEDs). Furthermore the wiring developed for the string is extremely flexible, allowing a uniform light distribution even in the most complex layouts and small signs. All LEDs are carefully selected from the same color range, ensuring visually consistent colors between the different sections and strings. Colors are also well maintained between different signs for consistent presentation of your customer's corporate identity.

For large and small channel letters

Thanks to the very small width of the LED devices (15 mm), the string easily fits into the narrowest channel letters while still providing uniform lighting. The small LED strings provide an excellent alternative to conventional neon or fluorescent lighting, which require much more space to make effective signs. The effectiveness of the system allows it to compete with neon even in large signs.

PHILIPS
sense and simplicity

Quality and cost savings for your customer

- Savings in energy consumption
- Savings in maintenance costs

Signs made with the Affinium LED string system offer an outstanding solution for your customer. Not only do they provide a reliable, high-quality brand presentation, they also offer significant savings on both energy and maintenance costs.

Savings in energy consumption

Energy consumption of the LED string is only around 3W per meter (e.g. for red), compared with 20W per meter for a neon lamp. This reduction of energy consumption with LED strings allows substantial savings to be made in operating costs.

Savings in maintenance costs

As well as immediate energy savings, the high reliability and long lifetime of LED strings also offer savings in maintenance costs. Both the LED strings and drivers are maintenance-free for up to 50,000 hours, whereas conventional systems often need replacing after just 20,000 hours. The lumen maintenance of the system is 50% at 50,000 hours at an ambient temperature of 70°C.

Tools to support your customer presentation

To help you in presenting your LED string proposition to your customers, Philips has developed two important tools.

1. LED Sign Advisor

The design of an LED string based channel letter is different from that of a traditional neon or fluorescent system. To help you create the optimal design that meets your customer's requirements, Philips has developed a unique LED string Sign Advisor. Based on the graphic format of your sign, this tool calculates the layout of the LEDs for optimal light distribution, as well as the total costs involved to realize this layout.

2. Cost savings calculator

Based on your customer's actual data and numbers, this tool provides insights into the actual savings that your customer can expect when selecting the Philips Affinium LED string system over a neon or fluorescent solution.

Guaranteed performance and service

The Philips Affinium LED string system gives you guaranteed performance – both of the products themselves and of our pre and after-sales service. Our guarantee is based on proven system reliability thanks to:

- Long lifetime of LEDs and all other components
- Exhaustive system testing
- Outdoor-proof to IP66 (both system and components)
- Excellent heat management

This guarantee ensures high customer satisfaction together with low service call rates for signmakers. For more information about the Philips Affinium LED string system guarantee, visit our website www.philips.com/signage or contact your distributor.

Applications in indoor and outdoor

- Sign lighting, channel letters of 0,3-2 meter high and band lighting

Compliances and approvals

- Safety EN 60598
- Endurance
 - High temp storage +100°C 96hrs IEC 68-2-1
 - Low temp storage -40°C 96hrs IEC 68-2-2
 - Damp heat 85%RH/85°C 96hrs IEC 68-2-3
 - Temp/shock -40°C/100°C 45'/45' 260 cycles IEC 68-2-14
 - Temp/cycle -20°C/+70°C
- Mechanical
 - Vibration and bump IEC 60068-2-29
(Affinium LED string tested with mounting clips)
- Quality
 - Ingress protection IP 66 (EN 60598, EN 60529)
 - Complying damp and wet locations
(ANSI/UL 2108, low voltage lighting systems)
 - Approval marks ENEC 05, UL recognition CSA approved
 - Quality standard ISO 9001-2000
 - Environmental standard ISO 14001
 - CE marking

Specification

Type	LED Power Driver	Wavelength nanometer nm	Color temp. Kelvin K	Power mW	Lumen per device Lm
Affinium LED string lp red P10	20W / 60W / 100W	624+/-10	-	270	7
Affinium LED string lp amber P10	20W / 60W / 100W	594+/-5	-	270	4.5
Affinium LED string lp blue P10	20W / 60W / 100W	476+/-7	-	250	2.8
Affinium LED string lp green P10	20W / 60W / 100W	526+/-7	-	250	6.3
Affinium LED string lp W6300 P10 (cool white)	20W / 60W / 100W	-	6300+/-700	170	5.8
Affinium LED string lp W3000 P10 (warm white)	20W / 60W / 100W	-	3000+/-175	170	5.0
Affinium LED string lp W8000 P10 (bluish white)	20W / 60W / 100W	-	8000+/-1000	170	5.8

Note: *Bluish white on request.*

Type	Lumen per meter Lm/m	Beam angle °	Case temp. max. °C	Ambient temp. range °C
Affinium LED string lp red P10	70	130	45	-20 / +70
Affinium LED string lp amber P10	45	130	45	-20 / +70
Affinium LED string lp blue P10	28	110	45	-20 / +70
Affinium LED string lp green P10	63	130	45	-20 / +70
Affinium LED string lp W6300 P10 (cool white)	58	110	45	-20 / +70
Affinium LED string lp W3000 P10 (warm white)	50	110	45	-20 / +70
Affinium LED string lp W8000 P10 (bluish white)	58	110	45	-20 / +70

Definitions

- String: Chain of sections
- Section: Chain of LED devices, always starting with LED Driver Device
- LED Driver Device: Encapsulated LED with integrated electronics = minimum operating string length on one LED Power Driver
- LED Device: Encapsulated LED without integrated electronics; can not operate without LED Driver Device



LED Device (LD)



LED Driver Device (LDD)

Dimensions

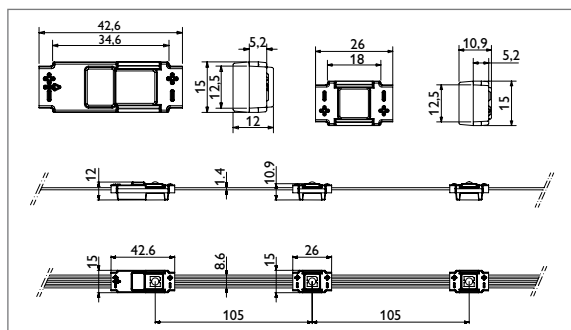

Optical characteristics

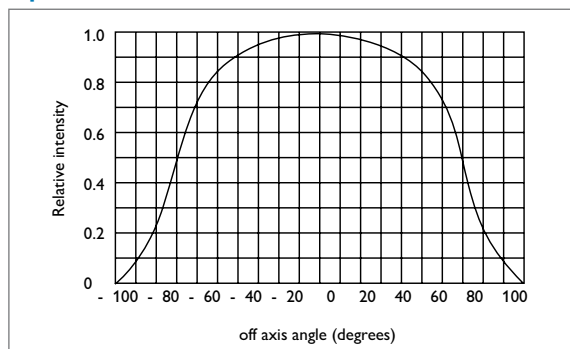

Relative intensity vs off axis angle for the colored LEDs

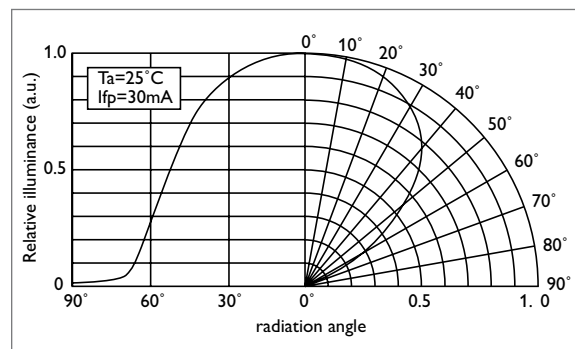

Relative illuminance vs radiation angle for the white LEDs

Quantities of LEDs per driver (for upto three branches*)

No extra wire

Affinium LED string	max nr. of LEDs	LED Power Driver		
		20W	60W	100W
whites (cool, warm and bluish white)	per driver ¹	120	344	536
	per branch ²	112	180	180
green	per driver ¹	88	256	404
	per branch ²	84	148	148
blue	per driver ¹	100	290	450
	per branch ²	95	140	140
amber	per driver ¹	75	235	370
	per branch ²	75	130	130
red	per driver ¹	80	240	380
	per branch ²	80	130	130

Note:

- per driver ¹ per driver the nr. of LEDs divided over the branches may not be exceeded and
per branch ² if more branches (upto 3) are used the nr. of leds per branch may not be exceeded
* if you want to apply more than 3 branches, please contact your local Philips office.

You can find information on extended cable lengths between drivers and LED strings in the technical application and installation manuals.

Installation example

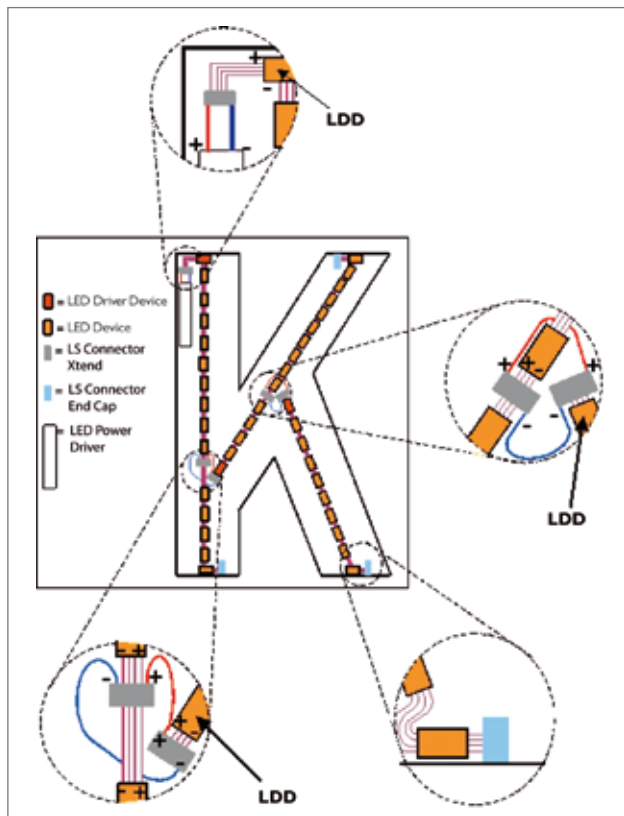

Constructing a channel letter using LED strings

More detailed information and installation advice in:

1. the technical application and installation manuals
2. the installation instructions added to the LED string packing
3. www.philips.com/signage or
4. via your distributor or local Philips office.

Note:

Please note that the LED string is only suitable for connection to a Class 2 power source (Philips LED power driver), with energy limited supply.

Ordering data

Affinium LED string	Box	Dimensions (cm.)			Weight	EOC
	packaging Qty	L	W	H	(kg)	8711559
Affinium LED string lp red P10	1x20 mtr	55	55	3.5	2	763675 00
Affinium LED string lp amber P10	1x20 mtr	55	55	3.5	2	763699 00
Affinium LED string lp blue P10	1x20 mtr	55	55	3.5	2	763712 00
Affinium LED string lp green P10	1x20 mtr	55	55	3.5	2	763736 00
Affinium LED string lp W6300 P10 (cool white)	1x20 mtr	55	55	3.5	2	763750 00
Affinium LED string lp W3000 P10 (warm white)	1x20 mtr	55	55	3.5	2	764429 00
Affinium LED string lp W8000 P10 (bluish white)	1x20 mtr	55	55	3.5	2	764986 00

Affinium LED string	Box	Dimensions (cm.)			Weight	EOC
	packaging Qty	L	W	H	(kg)	8711559
LS Mounting Clip	200 pcs	10	10	10	0.3	763910 30
LS Extension Cable 4W	50 mtr	18	18	1.5	0.75	763934 00
LS Connector Xtend+LS Applicator Tool ¹	10 pcs/1 pc	7.7	4.8	4.2	0.05	763972 30
LS Connector End Cap	10 pcs	7.7	4.8	4.2	0.05	763996 30
LS Mounting Tape 210 pads ²	1 reel of 210 pads	11	11	2.5	0.085	764016 00
LS Mounting Tape 1680 pads ²	1 reel of 1680 pads	25	25	2.5	0.68	764030 00
LS Connector Tool ³	1 pc	29	25	10	0.9	763958 00

¹ In each box of LS Connector Xtend an applicator is included to connect the strings and driver:

² The use of self adhesive tapes together with the LED string has been tested for stainless steel, aluminium and PMMA.

If other materials or coatings are used, please ensure that these are compatible with the adhesive tape.

If there is any doubt, use the dedicated mounting clips instead.

³ This tool can be ordered when many strings have to be connected (for small quantities you can use the LS Applicator Tool).

LED Power Driver (IP66)	Box	EOC
	packing	8711500
100-240V 20W-24V	10	911940 30
100-240V 60W-24V	10	911469 30
100-240V 100W-24V	10	911964 30

LED Power Drivers are advised for indoor and outdoor use (IP66).

In the USA Xitanium outdoor LED drivers can be applied.

Your distributor or local Philips Advance office can provide more detailed information.

For more information please visit:
www.philips.com/signage
www.asimpleswitch.com



© 2008 Koninklijke Philips Electronics N.V.
All rights reserved.

Document order number: 3222 635 57571
12/2008