

LCU 8020/00 - Push-button Interface

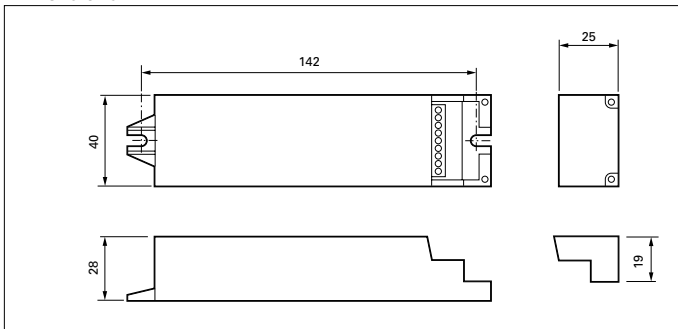

Dimensions in mm



PCB dimensions in mm

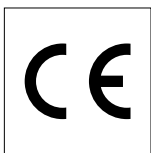
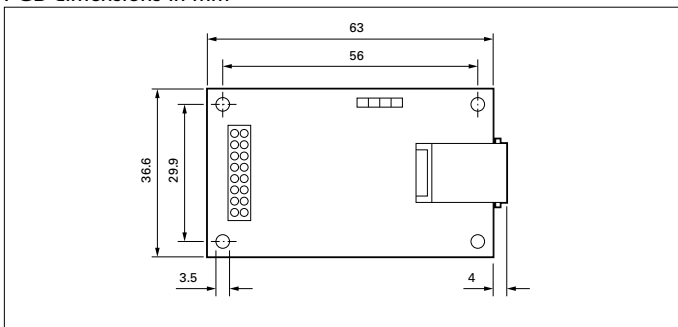

Product details

- The LCU 8020 is a small printed circuit board in a simple housing, that, on command of external contacts, generates RC5 codes suitable to drive the infrared receiver input of lighting control equipment. The unit enables the realization of customized or project specific solutions for push-button control and coupling to other (non-lighting) systems.
- If necessary for mechanical reasons, the printed circuit board can be taken out of its housing, reduced in size and mounted inside other equipment.
- The actual functions of the push-buttons are determined by the terminals they are connected to. An array of nine terminals is divided into a group of 4 (A,B,C,D) and a group of 5 (1,2,3,4,5). Push-buttons must always be connected between a terminal in the group of 4 and a terminal in the group of 5. Thus $4 \times 5 = 20$ different combinations (A1..D5) can be made, so a maximum of 20 push-buttons can be connected.
- The set of RC5 codes corresponding to the 20 combinations is fixed programmed in the memory of the unit. Five different sets of codes are stored in this memory, designated to IFS, to HELIO and TRIOS, to SCENIO, and to HVAC and other non-lighting functions. One set is spare. A rotary switch selects the code set in operation. For the full definition of the code sets refer to section "miscellaneous".
- All RC5 codes are generated in group "General".
- In order to facilitate the use of the LCU 8020 in a standard push-button panel, the codes for a set of seven preferred key-inputs have been allocated in such a way that these keys have a useful combination of functions in all 5 positions of the selector switch. These preferred keys correspond to input connections A1, B1, A2, B2, A3, B3 and A5.
- Some functions, e.g. "channel 1 on" and "channel 1 off", have been programmed both as two separate

- push-buttons and as one toggle button, providing maximum flexibility in control panel design.
- The unit comes complete with pull-relief and protective cover for the push-button connection cable.

Applications

- The Push-button Interface is used in those cases where the use of infrared transmitters is not feasible or not accepted due to customer preference, functionality, distance, risk of theft etc.
- Also in case of special requirements, such as coupling to other systems, the unit can be very useful.
- Main application is the fixed mounted and multi-point manual control of lighting installations.
- The unit can be used in combination with IFS, HELIO, TRIOS, and SCENIO, but also in combination with the RC5 decoder for control of HVAC and other non-lighting systems.
- The (external) push-buttons can be selected from available types as required or specified.
- Together with an appropriate set of push-buttons and the proper unit from the TRIOS or SCENIO range, the Push-button Interface provides an alternative for the LRP 23/LPB 81 combination, which was phased out after introduction of TRIOS LRC 1030/1035.
- When equipped with two push-buttons, the unit gives the function of a "digital potentiometer" which provides the function of multi-point manual dimming control.
- When the push-button inputs are connected to digital outputs (voltage-free contacts) of a building management system, various levels of system interaction can be realized.
- The Push-button Interface is available as component for system designers, engineers and installers for realization of project solutions in combination with different switching materials or in control panels, desks etc.

LCU 8020/00 - Push-button Interface

Related equipment

Lighting Management Systems:

IFS:	local units	BLU 10/11, BLU 10/12, BLU 10/13 DLU 10/01, DLU 10/31, LRC 4070
HELIO:	light controller	LRC 5040

Stand-alone control:

TRIOS:	light controllers	LRC 1010, LRC 1020, LRC 1030 LRC 1015, LRC 1025, LRC 1035
SCENARIO:	light controller extension module	LRC 1555 LRC 1505

General Purpose Components:

cables:	sensor cables branching connector	LCC 8011, LCC 8012, LCC 8013, LCC 8014, LCC 8024
sensors:	infrared receivers multi-sensor	IRR 8124, MCS 9010, MCS 9020 LRI 8133

Technical data

Input	: push-button contacts (normally open) V open : 5 Vdc I closed : 250 µA t closed min. : 50 ms	3. +5 Vdc supply voltage (n.a.) 4. light sensor output signal (n.a.) 5. infrared receiver output signal (RC5) 6. movement detector output signal (n.a.)
more push-buttons on one interface	: allowed	
more interfaces on one push-button	: not allowed.	
Output	: bi-phase RC5 codes	
output low voltage	: < 1.0 V	
output high voltage	: > 3.5 V	
max. output current sourced	: 10 mA	
max. output current sinked	: 0.1 mA	
short circuit current	: 50 mA (pin 5 of modular socket connected to ground). outputs can be "wired-or" up to a total of 6 interfaces one output can drive up to 5 controller inputs.	
Indicator	: red LED, indicating the generation of RC5 signals	
Power supply	: 12 Vdc ±10%, 5 mA derived from connected controller. short-circuit of supply < 1 A.	
Electrical connections		
Push-button inputs		
connectors	: 9 pole screw connector (can be replaced by header pins)	
wire size	: AWG 26 - 16	
stranded	: 1.0 mm ²	
solid	: 1.0 mm ²	
RC5 output	: modular socket ("Telejack") standard pinning: 1. 12 Vdc supply voltage 2. ground	
Housing	colour : white (90064) material : Lexan 161 R flame rating : UL 94 V2 glow wire test : 750 °C (IEC 695-2-1) ball pressure : 125 °C (IEC 335-1)	
Operating conditions	ambient temperature : +5 - +50 °C relative humidity : 20 - 85 %, no condensation	
Storage conditions	ambient temperature : -25 - +85 °C relative humidity : 10 - 95 %	
EMC	immunity : in accordance with EN 50082-1 radiated interference : in accordance with EN 50081-1 safety : Class III	
Reliability	call rate : 1% per year (estimated) life time : 10 years (estimated)	
Dimensions (l x w x h)	with housing : 159 x 40 x 28 mm without housing (small size) : 67 x 36,6 x 20 mm	
Weight	with housing : 77 g without housing (small size) : 15 g	
Mounting	with housing : two open-ended slots for 4 mm diameter screws without housing (small size) : 3,5 mm holes in the four corners of the PCB	

LCU 8020/00 - Push-button Interface

Packing data

Type	Box dimensions (mm)	Qty	Material	Weight (kg)	
				net	gross
Unit box	165 x 45 x 35	1	card board	0.1	0.15
Outer box	175 x 190 x 150	8	card board	0.8	1.4

Ordering data

Type	MOQ	Ordering number	EAN code level 1	EAN code level 3
LCU 8020/00	8	9137 003 07803	87 11559 51 6561	87 11559 51 6554

Miscellaneous

- To avoid synchronization problems, the use of (non-HVAC) toggle keys must be restricted to stand-alone systems e.g. TRIOS, or SCENIO. In that case it is only allowed to connect one LCU8020 to one or more roomcontrollers (Single Point Control). The use of other sensor types is not allowed when toggle keys are used.
- The RC5 outputs of a maximum of 6 push-button interfaces may be connected in parallel, in order to realize multi-point control.(Do not use toggle keys in this application).
- Maximum 3 push-button interfaces may be replaced by infrared receivers (Type IRR 8124, LRI 8133, MCS 9010 or MCS 9020), in order to realize combined push-button and infrared remote control.
Note: it is not allowed to use infrared receiver type IRR 04/01 or 14/01 in parallel to a push-button interface.
- One or more push-button interfaces can drive the inputs of a maximum of 5 controllers.
- The maximum distance between a push-button interface and a controller is 30 meters
- The maximum length of the total cable between push-button interfaces, infrared receivers and controllers is 125 meters.
- The maximum length of the total cable between one or more push-buttons and the push-button interface is 100 meters.
- It is not allowed to connect more than one push-button interface to one push-button.
- Push-buttons must preferably be "low level" types with a closed contact resistance of less than 4000 Ohm. Switching current is 250 μ A. The open line voltage is 5 Vdc. For reliable operation, the contact must be closed for more than 50 ms.
- The unit may be used in combination with MCS and DFS but then special precautions have to be taken with respect to electrical safety. As the interface does not add extra safety barriers to the basic insulation of MCS and DFS, push-buttons and other accessible conductive parts must be covered with supplementary insulation.
- The modular socket can be replaced by a 3 pole screw connector for the connection of the RC 5 output signal and the +12 V dc power supply.
- The printed circuit board allows for breaking away the part with the screw terminals, in order to reduce size for easy mounting inside other equipment. In this case header pins can be used instead of screw terminals for the connection of push-buttons.
- When the HVAC functions are used, 7 LED's or a 7 segment display must be connected for user feedback of the selected setpoint. The PCB has been prepared for extra header pins for the connection of a BCD to decimal decoder or a BCD to 7 segment decoder.
- For connection details of the header pins see figure 1 and tables 1 and 2 below.

Pin	Function
1	Ground
2	Input A
3	Input B
4	Input C
5	Input D
6	Input 1
7	Input 2
8	Input 3
9	Input 4
10	Input 5
11	HVAC output 0 (see table 2)
12	HVAC output 1 (see table 2)
13	HVAC output 2 (see table 2)
14	HVAC output 3 (see table 2)
15	+ 5 Vdc output (25 mA max)
16	Ground

Table 1: Functions of the header pins

Setting	HVAC outputs 3 2 1 0
HVAC Off	H H H H
Setpoint 1	L L L H
Setpoint 2	L L H L
Setpoint 3	L L H H
Setpoint 4	L H L L
Setpoint 5	L H L H
Setpoint 6	L H H L
Setpoint 7	L H H H

Table 2: Coding of the HVAC outputs

- H = High state
(the more positive voltage)
- L = Low state
(the less positive voltage)
- Ri = 1 KOhm

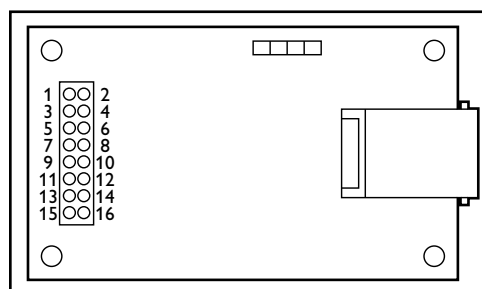

Figure 1: Location of the header pins

LCU 8020/00 - Push-button Interface

Table 5: CODE set 3 - SCENIO

	A		B		C		D	
1	Preset 1	30 03	Preset 2	30 04	Preset 7	30 18	Preset 8	30 19
2	Preset 3	30 00	Preset 4	30 07	Preset 9	30 20	Preset 10	30 21
3	Down Stop (toggle)	30 42 30 46	Up Stop (toggle)	30 41 30 46	Preset 11	30 22	Preset 12	30 23
4	Preset 5	30 16	Preset 6	30 17	Preset 13	30 25	Preset 14	30 26
5	All Off	30 63	Up	30 41	Down	30 42	Stop	30 46

Remarks: Toggle key A3 ("Down - stop") is automatically reset to the "Down" position each time any other key is pressed.
 Toggle key B3 ("Up - stop") is automatically reset to the "Up" position each time any other key is pressed.
 This automatic reset ensures logical operation after the up or down action was stopped by one of the other keys.

Table 6: CODE SET 4 - HVAC, WINDOW BLINDS, OFFICE EQUIPMENT

	A		B		C		D	
1	Preset 1	30 51	Preset 2	30 52	HVAC Comfort Temp. down	30 125 + NUM	HVAC Comfort Temp. up	30 125 + NUM
2	1 Off/Down	30 58	1 On/Up	30 57	Preset 1	30 51	Preset 2	30 52
3	Blinds Down Stop (toggle)	30 121 30 122	Blinds Up Stop (toggle)	30 120 30 122	1 Off/Down	30 58	1 On/Up	30 57
4	Blinds Down	30 121	Blinds Up	30 120	2 Off/Down	30 62	2 On/Up	30 61
5	All Off, Absent	30 63 30 127	Blinds Stop	30 122	All Off Absent	30 63 30 127	HVAC Standby	30 126

Remarks: Toggle key A3 ("Blinds Down - Stop") is automatically reset to the "Blinds Down" position each time key B3 ("Blinds Up - Stop") is pressed.
 Toggle key B3 ("Blinds Up - Stop") is automatically reset to the "Blinds Up" position each time key A3 ("Blinds Down - Stop") is pressed.
 This automatic reset eliminates synchronisation problems due to commands not generated with this push-button interface, e.g. blinds stopped by the end stop switch.

Keys C5 ("All Off, Absent") and D5 ("HVAC Stand-by") will switch off the setpoint indication LED's or 7 segment display.

LCU 8020/00 - Push-button Interface

Function of HVAC outputs

Table 3: CODE SET 1 – IFS

	A		B		C		D	
1	1 Off/ Down	30 58	1 On/ Up	30 57				
2	2 Off/ Down	30 62	2 On/ Up	30 61				
3	3 Off/ Down	30 60	3 On/ Up	30 59				
4								
5	All Off	30 63	1 On 1 Off (toggle)	30 37 30 58	2 On 2 Off (toggle)	30 61 30 62 (toggle)	3 On 3 Off	30 59 30 60

Remarks: IFS commands 1,2 and 3 can also be used for HELIO and Trios channel 1, channel 2 and channel 3.

Toggle keys B5, C5 and D5 are automatically reset to the "On" position, when key "All Off" (A5) is pressed. This automatic reset eliminates synchronization problems due to commands initiated by the "All Off" key.

Table 4: CODE SET 2 – HELIO/ TRIOS

	A		B		C		D	
1	Preset 1	30 51	Preset 2	30 52	Ch 3 Off/Down	30 60	Ch 3 On/Up	30 59
2	Preset 3	30 48	Preset 4	30 55	Ch 4 Off/Down	30 50	Ch 4 On/Up	30 49
3	Ch 1 Off/Down	30 58	Ch 1 On/Up	30 57	Ch 5 Off/Down	30 54	Ch 5 on/up	30 53
4	Ch 2 Off/Down	30 62	Ch 2 On/Up	30 61	Green button	30 56 30 58	Store	30 56
5	All Off	30 63	Preset 1 All Off (toggle)	30 51 30 63	All Off	30 63	Preset 1 Preset 2 (toggle)	30 51 30 52

Remarks: HELIO and Trios command Channel 1, Channel 2 and Channel 3 can also be used for IFS 1, 2, and 3.

Toggle keys B5 and D5 are automatically reset to the "Preset 1" position when key "All Off" (A5, C5) is pressed. This automatic reset eliminates synchronisation problems due to commands initiated by the "All Off" key.

LCU 8020/00 - Push-button Interface

3222 636 30081
 04/2001
 Printed in the Netherlands
 Data Subject to change
 www.controls4lighting.com

Table 7: CODE SET 5 – CENTRAL CONTROL WITH PUSH-BUTTON INTERFACE LCU 8020

This is a special mode for use in projects only. In this mode (5) the push-button interface LCU 8020 can be used for central control functions. For more detailed descriptions on the functionality and the installation is referred to the TRIOS- system handbook.

In the following table the general commands are displayed.

Required function	Terminals to be connected to common return				Transmitted RC5-code
	A	B	C	D	
Preset 1				•	30 51
Preset 2			•		30 52
Ch. 1 on			•	•	30 57
Preset 3		•			30 48
Ch. 2 on		•		•	30 61
Blinds down		•	•		30 121
Preset 4		•	•	•	30 55
All off	•				30 63
Blinds up	•			•	30 120
Ch.2 off	•		•		30 62
Ch.3 on	•		•	•	30 59
Ch.1 off	•	•			30 58
Ch.3 off	•	•		•	30 60
Blocking	•	•	•		29 101
Deblocking	•	•	•	•	29 102

Remark:

When terminals A plus B plus C are connected to the common return, a "BLOCKING" command will be sent to the TRIOS units. From that moment on, TRIOS will no longer react to any local or central command or any local sensor signal. The situation can only be released by sending the "DEBLOCKING" command (A plus B plus C plus D connected to the common return).

As an exception to the rule, parallel connection of the push-button interfaces is allowed, but only when using code set 5.

Related documentation

Installation instructions			3222 609 26451
Engineering and Service manual IFS		(English)	3222 635 09491
HELIO System Handbook	LCH 5900/00	(English)	9130 010 00003
HELIO Energy Saving Handbook	LCH 5915/00	(English)	9137 010 00203
SCENIO System Handbook	LCH 1599/00	(English)	9137 010 00403
Technical Application Manual Trios		(English)	3222 010 00403
TRIOS System Handbook	LCH 1099/00	(English)	9137 010 00503