

IRT8055/00

Infrared temperature transmitter



Description

The IRT8055/00 is a wall mounted, infrared temperature transmitter for the Helio Lighting Management System.

Features

- The IRT8055 is an infrared temperature transmitter for wall mounted applications.
- The transmitter has two temperature measurement ranges: 12.5°C .. 37.5°C (default) or 7.5°C .. 32.5°C, selectable by means of a DIP-switch in the battery compartment. See table 3, in the section "DIP-switch setting".
- Every 30 minutes the transmitter sends the actual temperature with a resolution of 0.1°C and transmits on a temperature difference of $\Delta = 0.3^\circ\text{C}$ (default) or $\Delta = 0.2^\circ\text{C}$ set by DIP-switch 8. See table 4, in the section "DIP-switch setting".
- The two large keys can also be used to control lighting, blinds and HVAC. The keys functions can be selected with 3 DIP-switches in the battery compartment. See table 2, in the section "DIP-switch setting".
- The group address can be selected with 3 DIP-switches in the battery compartment. See table 1, in the section "DIP-switch setting".
- The DIP-switches can be selected and batteries can be exchange without removing the unit from the wall.
- Battery life-time (with Philips Power Life Batteries – 1100 mAh) is 3 years for average use. See also Technical data.
- A red LED on the front of the transmitter indicates the proper transmission of infrared signals.
- Test mode by pressing both keys simultaneously.
- Battery low warning message.
- Out of temperature range warning message.

Applications

The IRT8055 measures the ambient room temperature. The two large keys can also be used to control lighting, blinds and HVAC (disabled in the factory setting). The transmitter should be mounted in such a way that it is not exposed to direct sunlight, high temperature, draft or humidity.

Related equipment

Helio Lighting Management System
Helio multi-sensor LRI5133

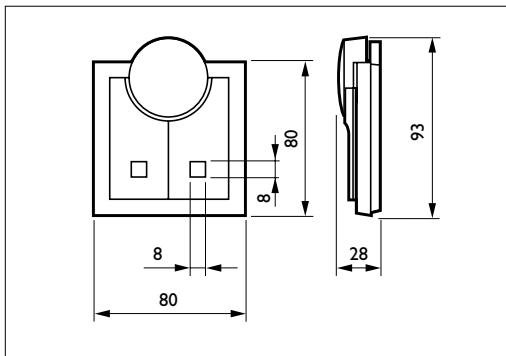

Dimensions in mm

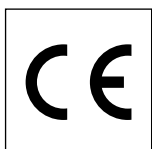

Technical data.

Number of keys: 2
 Number of indication LED's: 1 (red)
 Number of IR-LED's: 2
 Carrier frequency: 36 kHz. (RC5 standard)
 Supply voltage: 6.0 V nominal
 Number of batteries: 4 each 1.5 V nominal
 Battery type: LR03, AAA Philips Power life (1100mAh)
 Battery life time: 3 years ($\Delta = 0.3^{\circ}\text{C}$, default setting)
 2 years ($\Delta = 0.2^{\circ}\text{C}$)
 Battery low value: 4 Volt ($\pm 10\%$)
 Transmission time interval: Minimum 1 minute
 Maximum 30 minutes ($\pm 10\%$)

Environmental conditions

Operating conditions
 Temperature: 5...50 °C
 Relative humidity: 20...85 %
 Condensation: not allowed
 Direct sunlight: not allowed

Storage conditions

Temperature: -25...85 °C
 Relative humidity: 5...95 %

Dimensions: 93 x 80 x 28 mm
 (height x width x depth)

Weight: 0,070 Kg (without batteries)
 0,115 Kg (with batteries)

Housing

Material: ABS, Cycolac TCA
 Colour: White (Bayer 0177 – close to RAL 9010)
 Mounting : screws 3.5 to 4. mm. Diameter through mounting holes in battery compartment

EMC

Immunity: in accordance with EN 50082-1
 Radiated interference: in accordance with EN 50081-1

Reliability

Failure rate: 0.5% per year
 Life time: 10 years (average)

Installation

Opening the transmitter

In order to reach the mounting holes, set the functions address DIP-switches or insert the batteries, the unit shall be opened by using the keys as "doors". This can be done without any tool. See figure 1.

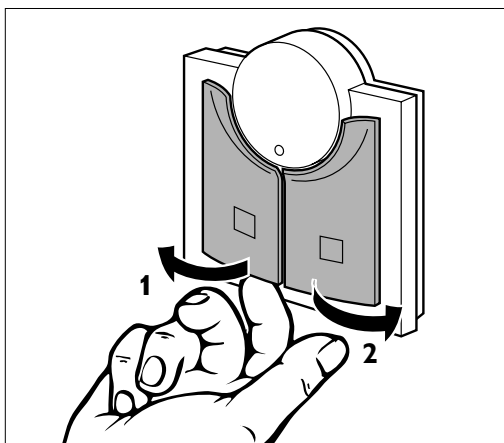

Figure 1: Opening the transmitter

Positioning the transmitter

The transmitter is only suitable for wall mounting. The transmitter must be located between 1 and 2 meter under the ceiling, on a representative wall for temperature measurement.

The corresponding receiver (Helio multi sensor) must be located in the ceiling, within the coverage area of the transmitter. See for detailed information figure 2, the installation instructions and technical note TN49004.

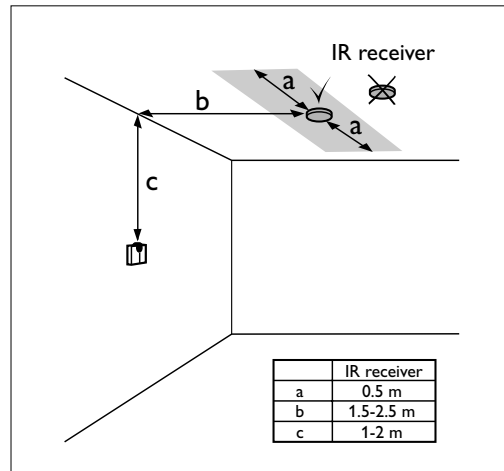

Figure 2: Positioning the transmitter

Mounting the transmitter

The transmitter can be fixed to the wall using round headed screws of 3.5 to 4.0 mm diameter or with two pieces double sided adhesive tape (60 x 19 mm). See figure 3.

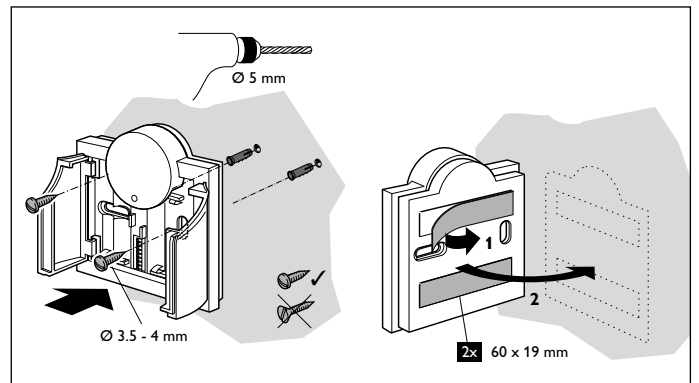

Figure 3: Fixation of the transmitter

Battery handling

All batteries must be replaced simultaneously. Always use a set of 4 new batteries from the same brand with the same production date. Please make sure that the batteries are inserted with the correct polarity. Inverted batteries may cause damage to the transmitter. Disposal of batteries must be in accordance to local regulations (see installation instructions).

DIP-switch setting.

There are 8 DIP-switches to set different functions of the transmitter. The DIP-switches are located in the battery compartment.

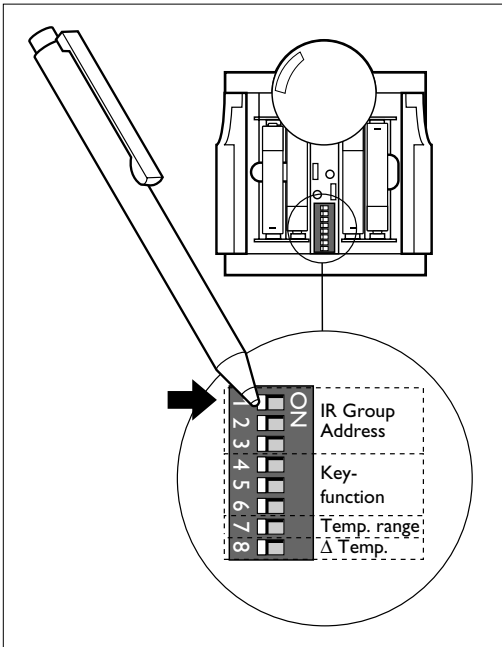

Figure 4: DIP-switch setting

Group address selection

DIP-switch 1, 2 and 3 are used to set the IR-group address.

Helio-groups address	Dip switch position		
	1	2	3
A			
B	ON		
C		ON	
D	ON	ON	
E			ON
F	ON		ON
G		ON	ON
ALL	ON	ON	ON

Table 1: Group address selection

Keys functions

DIP-switch 4, 5 and 6 are used to set the keys functions.

Left key	Right key	Dip switch position		
		4	5	6
-	-			
CH1 off/down	CH1 on/up	ON		
CH2 off/down	CH2 on/up		ON	
ALL off	Preset 1	ON	ON	
ALL off	Preset 1, 2, 3, 4 *			ON
Absent	Present	ON		ON
Blinds down	Blinds up		ON	ON
Fan off	Fan on	ON	ON	ON

Table 2: Keys functions

* Multiple touch keys:

A sequence of 1, 2, 3, or 4 short key presses will call different presets. Time between two subsequent presses must be less than approx. 0.5 seconds

Temperature range

DIP-switch 7 is used to choose another temperature measurement range.

	7
Temp. range 12.5°C ... 37.5°C	
Temp. range 7.5°C ... 32.5°C	ON

Table 3: Temperature range

Important: If DIP-switch 7 is set in the "ON" position (7.5°C ... 32.5°C), please take into account that the midpoint value of the Helio multi-sensor has to be changed from 25°C to 20°C.

Transmission on temperature delta

DIP-switch 8 is used to choose another temperature delta for transmission.

	8
Δ 0.3 °C	
Δ 0.2 °C	ON

Table 4: Transmission on temperature delta

DIP-switch 8: "OFF"

The transmitter measures the ambient temperature every minute. In case the temperature difference is $\geq 0.3^{\circ}\text{C}$ compared to the previously transmitted temperature value, it transmits the actual value to the Helio multi-sensor.

In case the temperature difference is $< 0.3^{\circ}\text{C}$ the actual temperature value is transmitted every 30 minutes.

DIP-switch 8: "ON"

The transmitter measures the ambient temperature every minute. In case the temperature difference is $\geq 0.2^{\circ}\text{C}$ compared to the previously transmitted temperature value, it transmits the actual value to the Helio multi-sensor.

In case the temperature difference is $< 0.2^{\circ}\text{C}$ the actual temperature value is transmitted every 30 minutes.

Memo card

Memo cards (see figure 5) are printed at the rear side of the keys. The card on the left key shows the address setting. The 7 possible keys functions and temperature settings are to be found in the right key. Space has been reserved to mark the settings used.

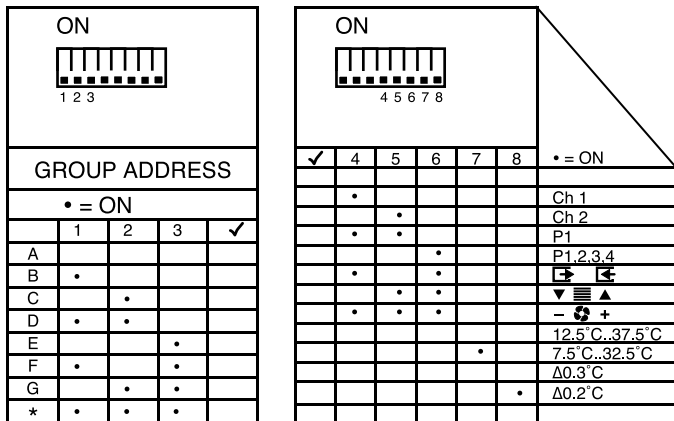

Figure 5: Memo cards at rear side of keys

Diagnostics

Transmission indication

The red LED indicates transmission of IR messages.

Battery low indication

The transmitter measures the battery voltage with an average time interval of 5 days. When the "temperature delta" is set on 0.2 °C degrees the average time interval is 4 days. If the battery voltage becomes too low, the transmitter sends an alarm signal message, which can be used by the building management system. See technical note TN49005 for RC5 code information.

Out of temperature range

If the ambient temperature goes under or above the selected measuring range, the transmitter sends an alarm message, which can be used by the building management system. See technical note TN49005 for RC5 code information.

Test mode

In case both keys are pressed simultaneously, the transmitter measures and transmits the actual room temperature and a battery low alarm, if applicable, to the building management system. As long as the two keys are pressed the transmitter keeps measuring and transmitting the temperature every 5 seconds.

Packing data

Type	Box dimensions (mm)	Qty	Material	Weight (Kg)	
				net	gross
Unit box	124 x 92 x 50	1	card board	0.115	0.160
Outer box	205 x 192 x 133	8	card board	0.92	1.380

Ordering Data

Type	MOQ	Ordering number	EAN code level 1	EAN code level 3
IRT8055/00	8	9137 003 16803	87 11559 518435	87 11559 518442

Related documentation

Technical note: IRT8055 detailed mounting instructions	TN49004 *
Technical note: IRT8055 RC5 transmission codes	TN49005 *
Installation instruction	3222 636 40121

Remark:

All documents available on internet/intranet

* data subject to be change