

LRL5002/I0

Solar level detector



General Description

The solar level detector monitors the level of ambient light at its location. More than one solar level detector may be used to monitor daylight levels in different areas, or aspects of a building. The unit provides input to the lighting management system in order to allow use of local light level information. The detector is normally connected to the sensor input of a Lighting Control Module (LCM). The LRL5002 can be used with the LightMaster Modular; WireMaster Plus and LightMaster I00 systems.

Location

The solar level detector is suitable for either external or internal mounting, and should be mounted where it observes a good sample of the level of daylight entering the building. This is normally achieved by locating the detector inside and close to the glazing. However, the detector can also be mounted in a remote location, e.g. the roof. In all locations care should be taken to avoid interference by either dark shadows produced by nearby buildings and trees or light from external sources (e.g. street or flood lighting) that are not consistent with the area under control. If one solar level detector is to control a large area, then mount the unit facing North, and adjust the solar level controls in the front-end software to compensate. Avoid locations that expose the detector to direct sunlight.

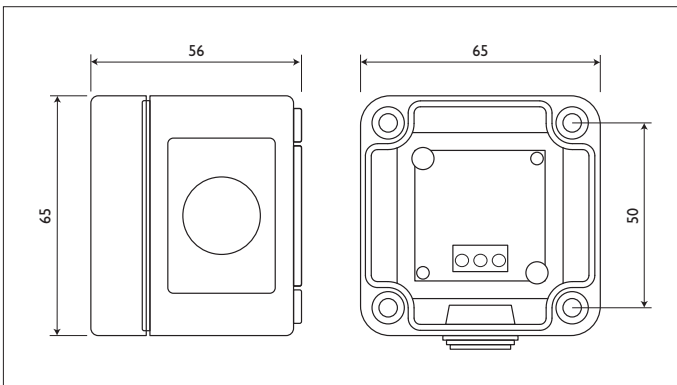

Dimensions in mm

Installation and Wiring

In applications where the solar level detector is located close to a LightMaster Modular lighting control module a RJ-12 sensor cable (plug/free wires) can be used to connect the unit's terminals to the RJ-12 socket on the LCM. Alternatively, if the unit is remotely mounted then a separate 3 core mains rated cable, typically 1.5mm², should be used to connect a solar level detector to a modular junction box (6 connections) adjacent to an LCM. This 3 core cable can be run in the same containment system with mains cables. The modular junction box is then connected to an LCM by a sensor cable using the modular plug-in connectors (RJ-12). This sensor cable cannot be run in the same containment with mains cables. It is advised to use the 3 core mains rated cable for the larger part of the connection and use the sensor cable only for the last part of the connection to the LCM.

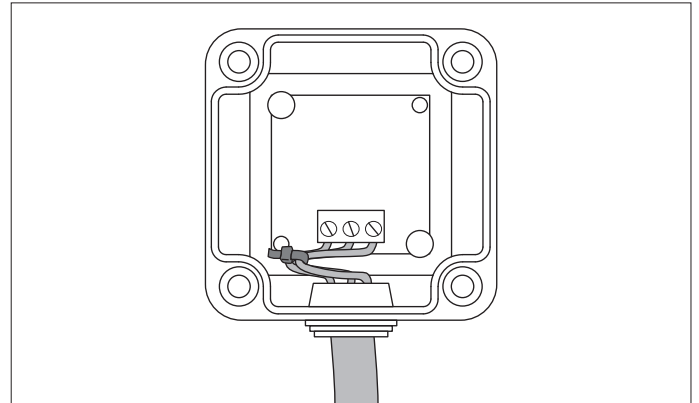

Connections on solar level detector

The 3 cores of the cable connected to the detector are connected to the junction box as shown in the table below:

Solar level detector	LMM LCMs (Modular junction box No./wire colour)	WireMaster Plus ASU	LightMaster 100 LCMs
0/P	4 (green)	ON	1 (ON)
0V	2 (black)	0V	0V
+V	1 (white)	24V	15V

Telejack connectors

Pin/core	Colour wire	Function
1	White	12VDC
2	Black	GND
3	Red	5VDC
4	Green	LS
5	Yellow	IR
6	Blue	MD

Sensor cable connection

Mounting and wiring the sensor: Remove the outer cover and gasket assembly by loosening (do not remove) the two screws. Secure the housing in position by carefully drilling through two of the four corner fixing holes. Terminate the cables in the sensor in the connector on the PCB and relocate cover and gasket assembly. Ensure gasket is seated correctly and waterproof enclosure is intact.



Modular junction box

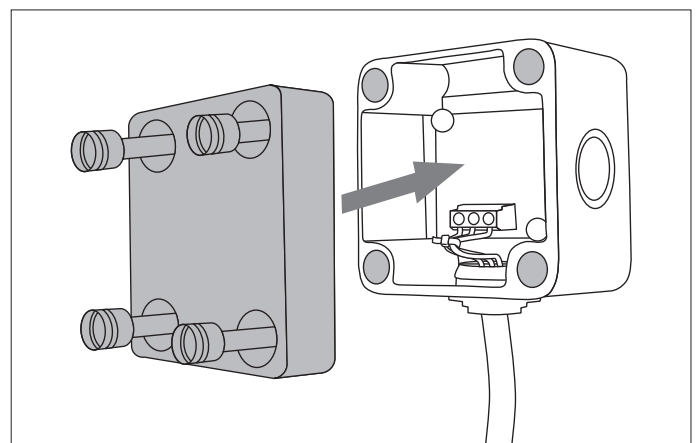

LRL5002 cover

As a guideline for setting the reference level in the front-end software the indicative graph below can be used. The value on the y-axis is the voltage on the '+V' contact of the detector:

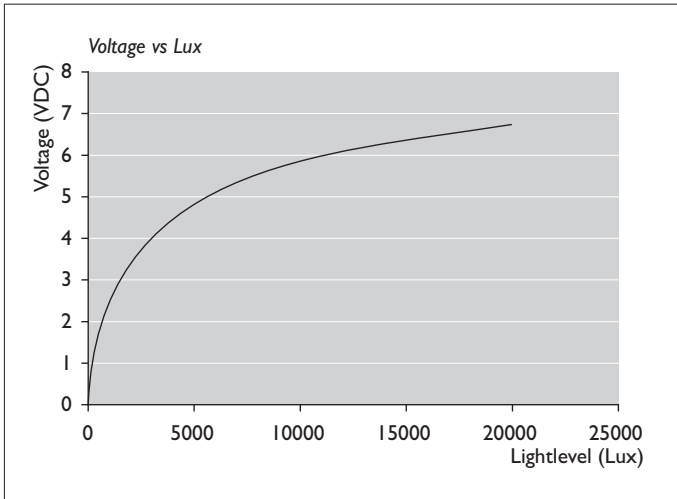

Technical data

Colour	Grey
Operating Temperature	-15°C...+50°C
Storage Temperature	-25°C...+85°C
Operating voltage	11...24VDC
Operating current	5...7mA
IEC protection class	Class III
Pollution degree	4
Ingress protection	IP65
Marking	CE

Packing data

Type	Box dimensions (mm)	Qty	Material	Weight (Kg)	
				net	gross
Unit box	80 x 72 x 70	1	card board	0.11	0.15

Ordering Data

Type	MOQ	Ordering number	EAN code level 1	EAN code level 3	EOC
LRL5002/10	1	9137 003 30703	87 11559 731858	87 11559 731865	731858 99

3222 636 30621
 10/2007
 Data subject to change
 www.philips.com/lightingcontrols

